

Service Manual

Compact Disc Changer

Compact Disc Player

SL-CH515



MASH*1
multi-stage noise shaping

Colour

(K) Black Type

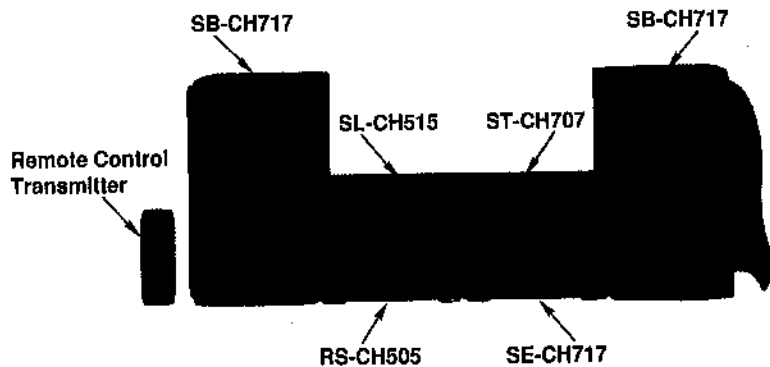

*The photograph shows the SC-CH717 model.

Area

Suffix for Model No.	Area	Colour
(E)	Europe, Oceania	(K)
(GC)	Asia, Latin America, Middle Near East and Africa	

**System: SC-CH515
SC-CH717**

Because of unique interconnecting cables, when a component requires service, send or bring in the entire system.

NEW TRAVERSE DECK (RAE0113Z)

Specifications

- Audio
DA converter 1 bit 2 DAC MASH
- CD Graphics for (GC) area
Video format NTSC (M)/PAL (B, D, G, H, I)
- Pickup
Wavelength 780 nm
- General
Dimensions (W×H×D) 270×89×320 mm
Weight 2.9 kg

Notes:

1. Weight and dimensions shown are approximate.
2. Design and specifications are subject to change without notice.

*1 MASH is a trademark of NTT.

System	Tuner/Sound Processor	Compact Disc Player	Amplifier	Cassette Deck	Speakers
**SC-CH515	ST-CH505	SL-CH515	SE-CH515A	RS-CH505	**SB-CH515A
**SC-CH717	ST-CH707		SE-CH717		SB-CH717
**SC-CH717	ST-CH505				

Notes: **for Europe area
**for Asia, Latin America, Middle Near East and Africa area
**for Oceania
**Made in PAES

Technics

■ Contents

	Page		Page
● HANDLING PRECAUTIONS FOR TRAVERSE DECK	2	● WIRING CONNECTION DIAGRAM	35
● PRECAUTION OF DIODE	2, 3	● MEASUREMENTS AND ADJUSTMENTS	36, 37
● LOCATION OF CONTROLS	3, 4	● ABOUT THE SELF-DIAGNOSTIC MODE	38, 39
● LISTENING TO COMPACT DISCS	4~6	● DISPLAY FUNCTION OF AUTOMATICALLY-ADJUSTED RESULTS	40
● DISASSEMBLY INSTRUCTIONS	7~14	● NEW DIGITAL SERVO SYSTEM	41
● HOW TO CHECK THE SERVO AND MAIN P.C.B.	15, 16	● TROUBLESHOOTING GUIDE	42, 43
● INSTALLATION OF THE LOADING COMPONENTS	16~18	● WHAT IS CD GRAPHICS	44~47
● INSTALLATION OF THE TRAY BASE AND THE TRAY ASS'Y	18	● FUNCTION OF IC TERMINALS	48~53
● BLOCK DIAGRAM	19~22	● REPLACEMENT PARTS LIST	54~58
● SCHEMATIC DIAGRAM	23~30	● CABINET PARTS LOCATION	59, 60
● PRINTED CIRCUIT BOARD DIAGRAM	31~34	● LOADING UNIT PARTS LOCATION	61

NOTE:

Refer to the service manual for Model No. SE-CH515A (Order No. DA9312323C2) or SE-CH717 (Order No. AD9312322C3) for information on "ACCESSORIES", "STACKING THE COMPONENTS", "CONNECTIONS" and "PACKING".

■ Handling Precautions for Traverse Deck

The laser diode in the traverse deck (optical pickup) may break down due to potential difference caused by static electricity of clothes or human body.

So, be careful of electrostatic breakdown during repair of the traverse deck (optical pickup).

● Handling of traverse deck (optical pickup)

1. Do not subject the traverse deck (optical pickup) to static electricity as it is extremely sensitive to electrical shock.
2. To prevent the breakdown of the laser diode, an anti-static shorting pin is inserted into the flexible board (FPC board). When removing or connecting the short pin, finish the job in as short time as possible.
3. Take care not to apply excessive stress to the flexible board (FPC board).
4. Do not turn the variable resistor (laser power adjustment). It has already been adjusted.

● Grounding for electrostatic breakdown prevention

1. Human body grounding
Use the anti-static wrist strap to discharge the static electricity from your body.
2. Work table grounding
Put a conductive material (sheet) or steel sheet on the area where the traverse deck (optical pickup) is placed, and ground the sheet.

Caution:

The static electricity of your clothes will not be grounded through the wrist strap. So, take care not to let your clothes touch the traverse deck (optical pickup).

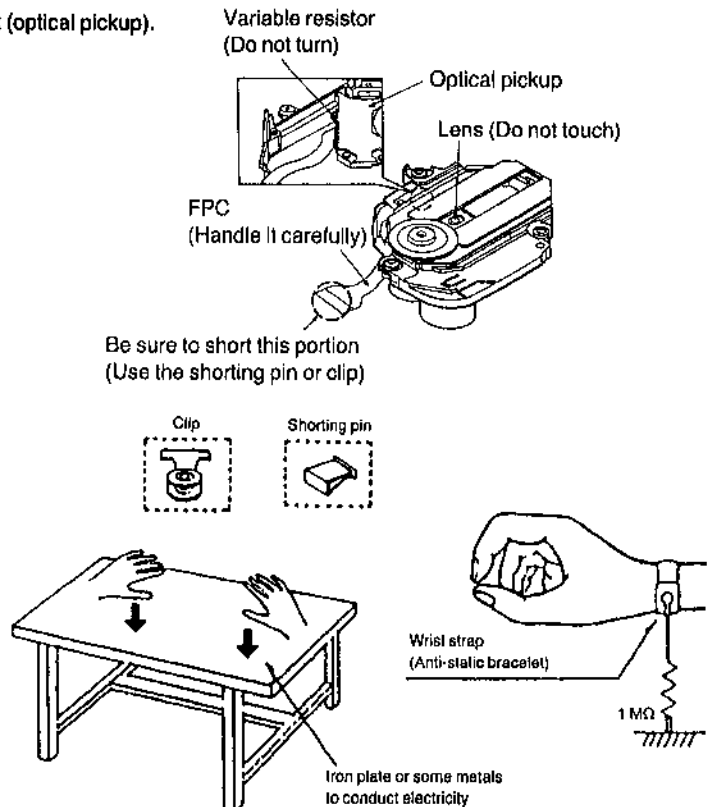

■ Precaution of Laser Diode

CAUTION: This product utilizes a laser diode with the unit turned "on", invisible laser radiation is emitted from the pick up lens.
Wave length: 780 nm
Maximum output radiation power from pick up: 100 μ W/VDE

Laser radiation from the pick up unit is safety level, but be sure the followings:

1. Do not disassemble the optical pick up unit, since radiation from exposed laser diode is dangerous.
2. Do not adjust the variable resistor on the pickup unit. It was already adjusted.
3. Do not look at the focus lens using optical instruments.
4. Recommend not to look at pick up lens for a long time.

ACHTUNG: Dieses produkt enthält eine laserdioden. Im eingeschalteten zustand wird unsichtbare laserstrahlung von der lasereinheit abgestrahlt.

Wellenlänge: 780 nm

Maximale strahlungsleistung der lasereinheit: 100 µW/VDE

Die strahlung an der lasereinheit ist ungefährlich, wenn folgende punkte beachtet werden:

1. Die lasereinheit nicht zerlegen, da die strahlung an der freigelegten laserdioden gefährlich ist.
2. Den werkseitig justierten einstellregler der lasereinheit nicht verstellen.
3. Nicht mit optischen instrumenten in die fokussierlinse blicken.
4. Nicht über längere zeit in die fokussierlinse blicken.



**LUOKAN 1 LASERLAITE
KLASS 1 LASER APPARAT**

Heat prevention
cover

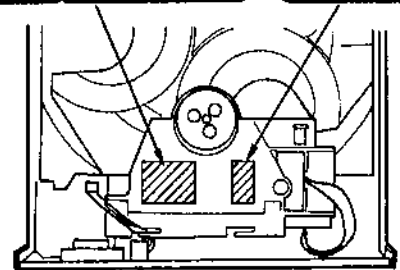
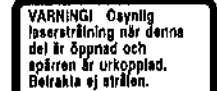
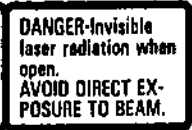
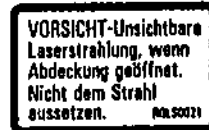
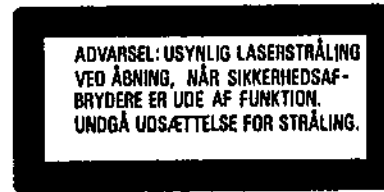
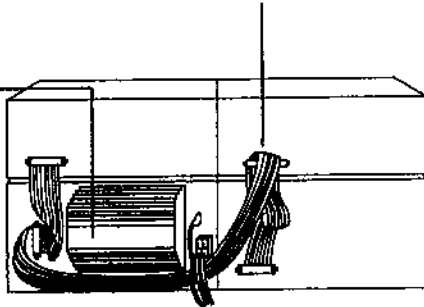

■ Location of Controls

- 1 Disc buttons
- 2 Stop button
- 3 Skip/search buttons
- 4 Loading drawer open/close button
- 5 Compact disc edit buttons
- 6 Display button
- 7 Random play button
- 8 Repeat play button
- 9 Pause button
- 10 Play button and indicator

The functions indicated by the numbers with black background (for example 1) can also be activated from the remote control transmitter.

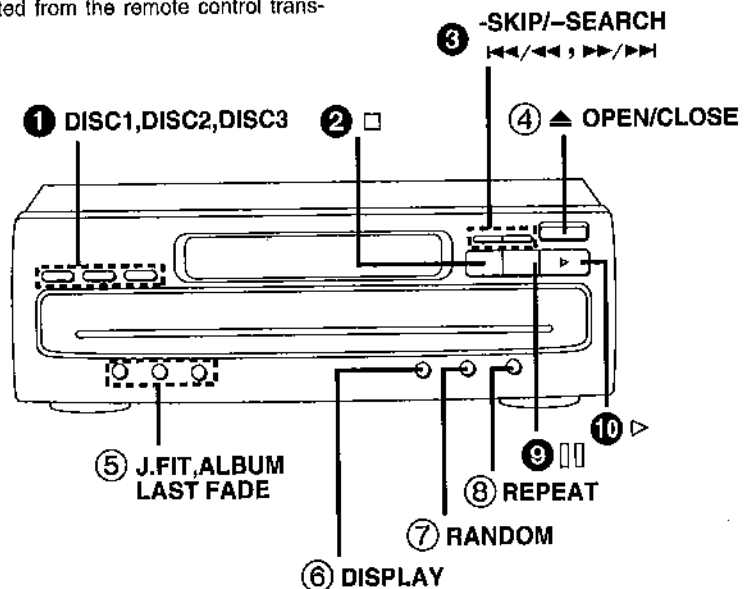

CD Graphics (For areas except Australia and New Zealand)

This unit has CD Graphics function. You can enjoy karaoke complete with visual imagery and the text by connecting your TV set to this unit. Use CDs marked **GRAPHICS** to enjoy CD graphics.

Notes

- Use CDs marked **GRAPHICS** to enjoy CD graphics. No picture will appear with CDs which are not marked in this way.
- Skipping forward or backward during CD graphics play may cause the picture to shift for a short period of time. This is not indicative of malfunctioning. If play is left to continue, the picture will return to normal.
- This unit does not come with a graphics channel selection or fade-out function.
- Set the CD changer according to the television set.
NTSC: When receiving NTSC signals
PAL: When receiving PAL signals
- For details, see the operation manual of the television set.

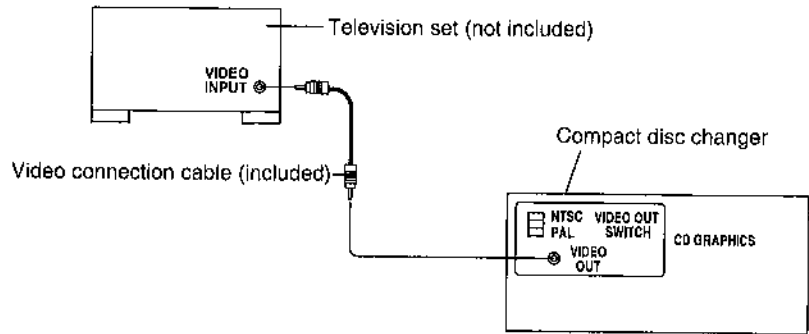

■ Listening to Compact Discs

Sequential play

Sequential play refers to play all tracks on the loaded discs in sequence beginning with the first track of the first disc and continuing in order to the last track of the last disc.

- 1 Switch on the power on the amplifier.**
- 2 Press \blacktriangle OPEN/CLOSE to open the loading drawer.**
- 3 Load the disc(s) on the disc tray(s).**
Do not load 8 cm (3") and 12 cm (5") discs on the same disc tray.
Be sure to load a 8 cm (3") disc correctly at center position.
- 4 Press \blacktriangle OPEN/CLOSE to close the loading drawer.**
- 5 Press \blacktriangleright .**
Disc play begins from the first track on the first disc.
Play stops automatically when the last track on the last disc finishes playing.
- 6 Adjust the volume level as you like on the amplifier.**

To stop the disc play:

Press \square .

To temporarily stop the disc play:

Press \square .

\blacktriangleright indicator flashes.

To play again, press \blacktriangleright .

For your reference:

If you press \blacktriangleright instead of \blacktriangle OPEN/CLOSE after inserting disc(s), the loading drawer will close and play will start directly.

The compact disc will automatically stop when a different sound mode is selected during its operation.

(To be continued)

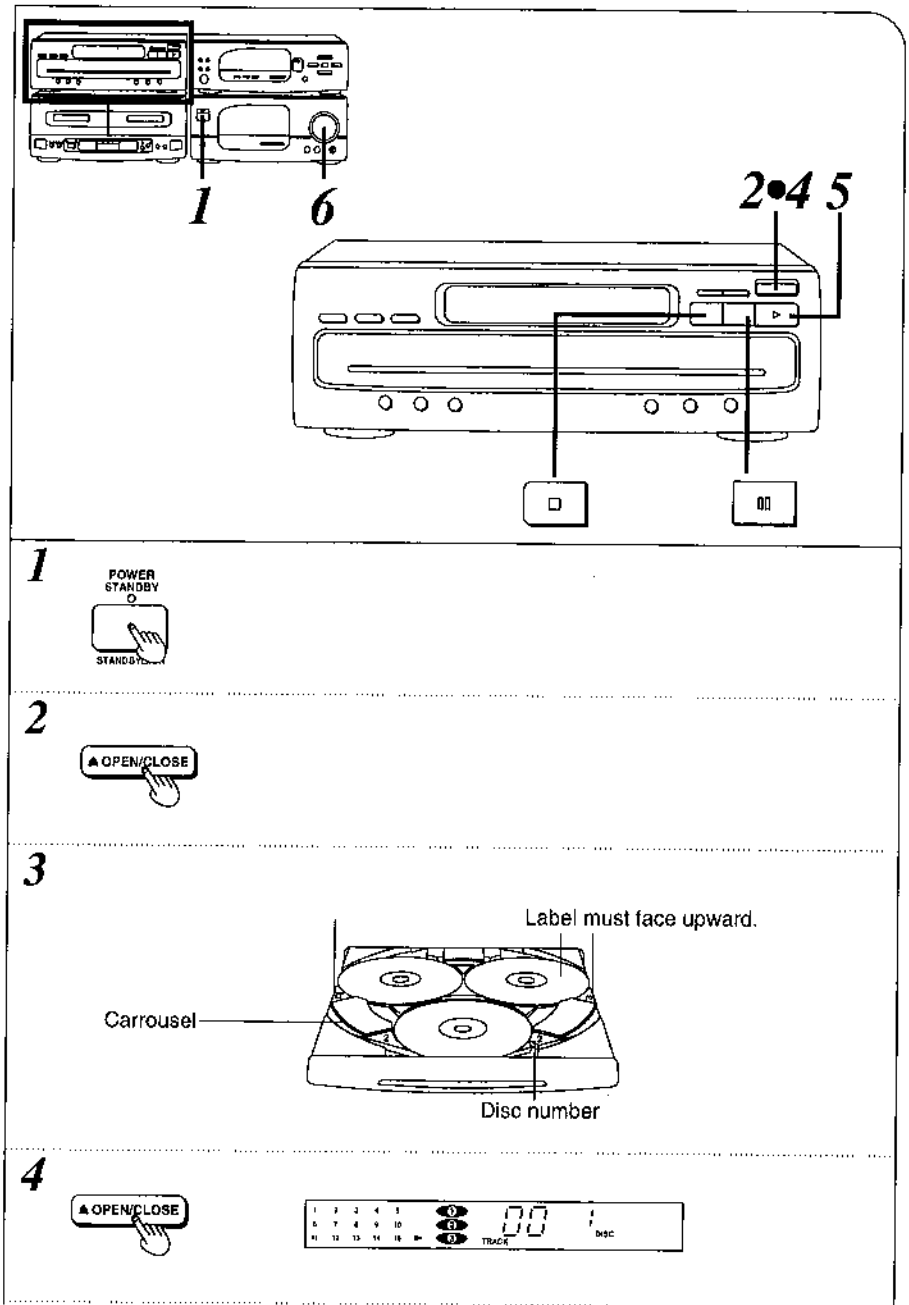

5

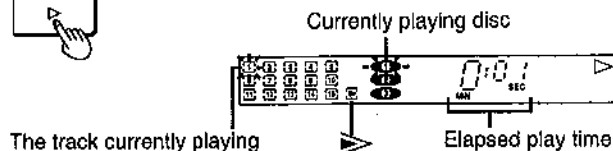

6

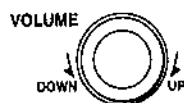

(Continued)

About ▷ Indicator:

While halted: Lights in orange.

While playing: Lights in green.

When "▷" appears on the display:

It indicates there are 16 or more tracks on the disc at the playing position.

Concerning the total playing time on the display:

The total playing time displayed includes the silent sections between tracks. Hence, there will be a difference between the total playing time and the liner notes included with the disc.

Notes

- Do not cover the hole or slits. Otherwise the incorrect operation will take place.
- Do not insert another disc onto tray placed at ①, although the tray is partially showing, its disc is in the play position. **A**
- Be sure to load the discs correctly in the center position as shown in the drawing. **B**
- Do not touch the carousel or the loading drawer while it is moving.
- Do not turn the tray forcibly by hand because it may fail to operate normally.
- If the discs are not correctly loaded, play may not start. In such a case, reinsert the disc as following.
 1. Switch the power to the standby mode on the amplifier, and then back on.
 2. Press OPEN/CLOSE to open the loading drawer.
 3. Load the disc(s) on the tray(s) correctly.
- If you press OPEN/CLOSE while the play indicator (▷) is lit in green, the drawer will open to half position. To open fully, follow the procedure below.
 1. Press □.
 2. Press OPEN/CLOSE to close the loading drawer.
 3. Press OPEN/CLOSE again to open the drawer.
- Do not move this changer with a compact disc inside the unit. If a disc comes off the disc tray, it might be scratched or the changer might become incapable of playing.

(To be continued)

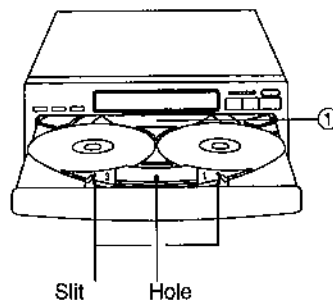
A**B**

8 cm (3") CD

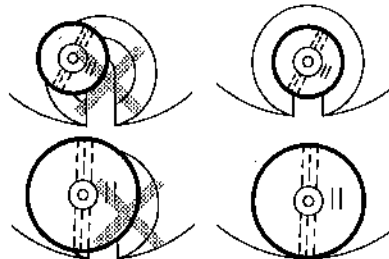

12 cm (5") CD



(Continued)

To select the desired disc **A**

Press DISC1, DISC 2 or DISC 3 to select the disc which you want to play.
The play will automatically start from the first track of the disc you select.

To confirm the total playing time of the disc currently playing

Press DISPLAY.
The display will change (as described below) each time you press the button.

In the stop mode: **B**

- ① The display shows the total playing time of the disc at the playing position.
- ② The display shows the disc number and the total track number of the disc currently playing.

In the play mode: **C**

- ① The display shows the track number of the disc at the playing position.
- ② The display shows the elapsed time of the track currently playing.

To exchange discs during play

While a disc is playing, you can exchange discs.

- 1. Press OPEN/CLOSE during playing.
The loading drawer will open at half position.
- 2. Exchange the discs.
- 3. Press OPEN/CLOSE again to close the loading drawer.

After the last track on the current disc finishes playing, the changer will play all the remaining disc(s) loaded, and then stop.

Note

If you play a disc with the loading drawer open, the changer will automatically stop when the last track on the current disc finishes playing.

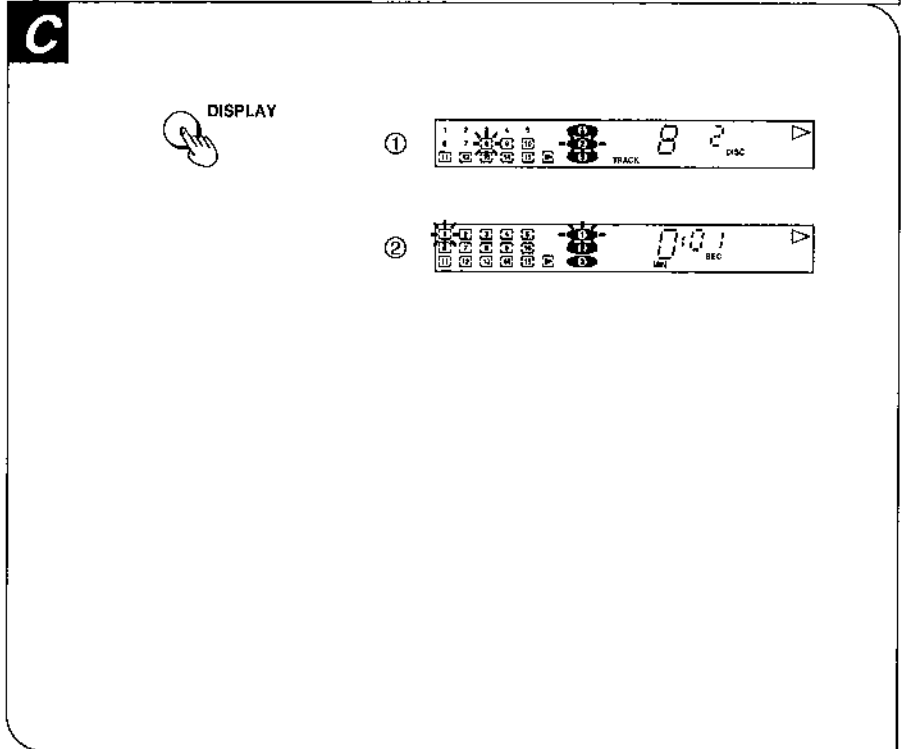
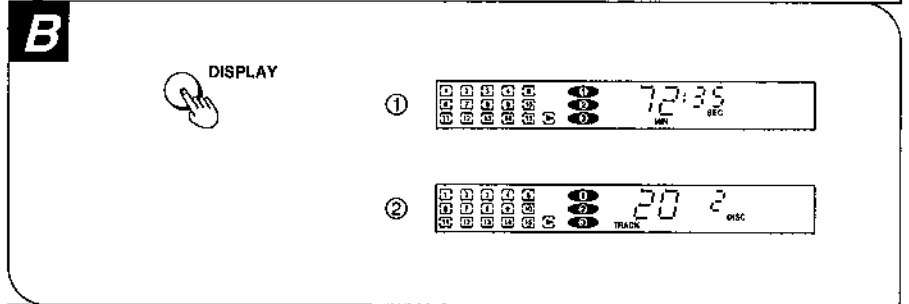
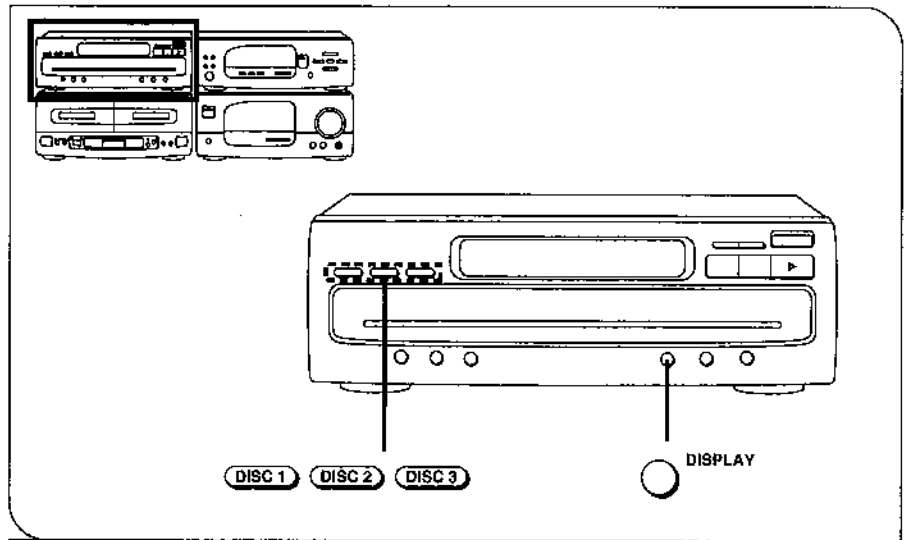

Disassembly Instructions

Warning: This product uses a laser diode. Refer to caution statements on page 2.

ACHTUNG: Die Lasereinheit nicht zerlegen.

Die Lasereinheit darf nur gegen eine vom Hersteller spezifizierte Einheit ausgetauscht werden.

"ATTENTION SERVICER" Some chassis components may have sharp edges. Be careful when disassembling and servicing.

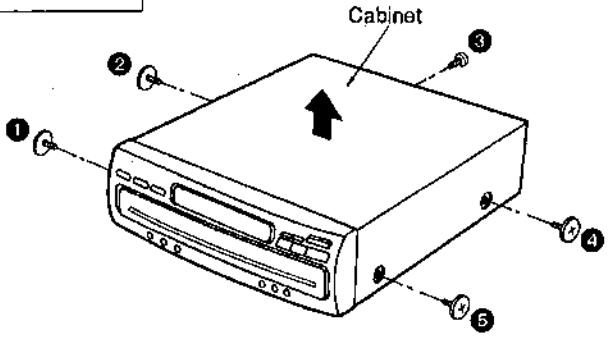
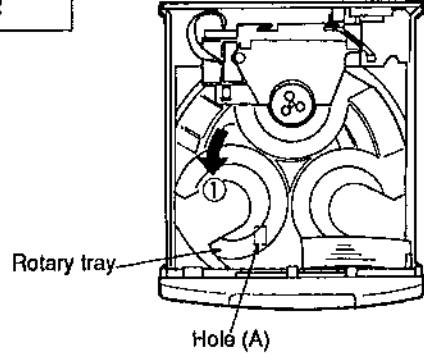
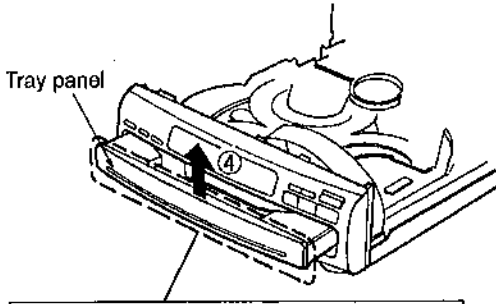
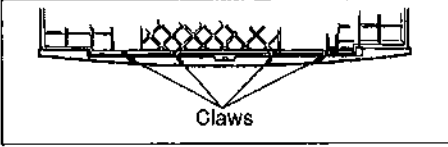
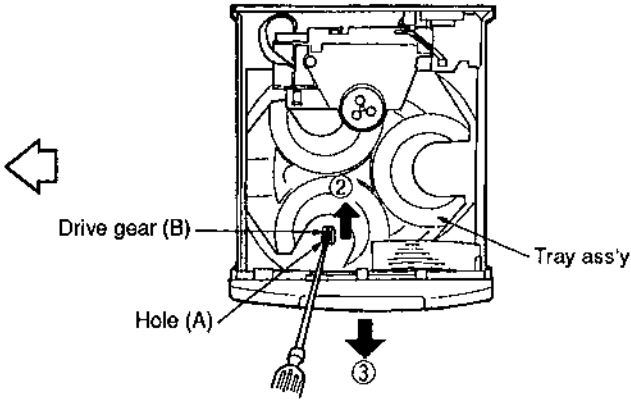
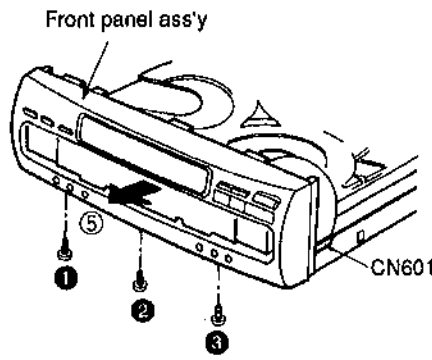
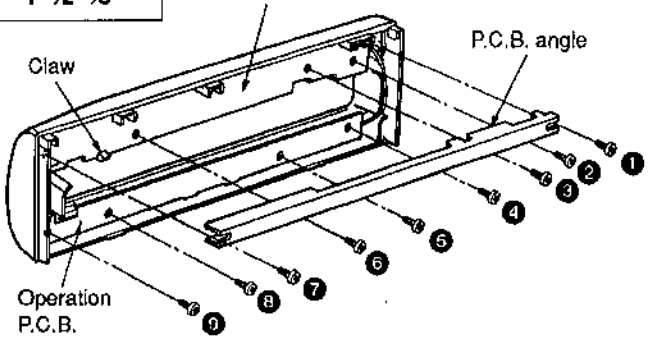
Ref. No. 1	Removal of the Cabinet	Ref. No. 2	Removal of the Front Panel Ass'y
Procedure 1	 <p>1. Remove the 5 screws (①~⑤).</p> <p>2. Remove the cabinet in the direction of arrow.</p>	Procedure 1→2	 <p>1. Rotate the rotary tray to the position that can be confirmed the hole (A) in the direction of arrow ①.</p>
	  <p>3. Remove the 4 claws and then remove the tray panel in the direction of arrow ④.</p>		 <p>2. Pressing the drive gear (B) in the direction of arrow ② with inserting the (-) screwdriver in the hole (A), the tray ass'y moves slightly in the direction of arrow ③.</p>
	 <p>4. Remove the 3 screws (①~③).</p> <p>5. Remove the 1 connector (CN601).</p> <p>6. Remove the front panel ass'y in the direction of arrow ⑤.</p>	Ref. No. 3	Removal of the Operation P.C.B. and FL P.C.B.
		Procedure 1→2→3	 <p>1. Remove the 9 screws (①~⑨).</p> <p>2. Remove the P.C.B. angle.</p> <p>3. Release the 1 claw.</p>

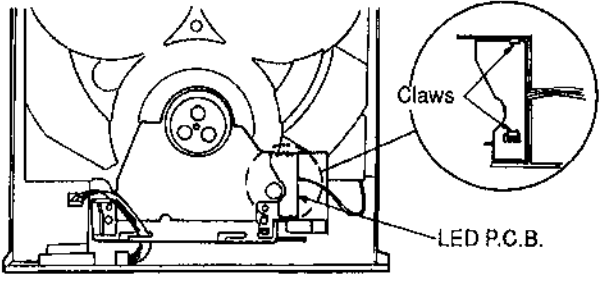
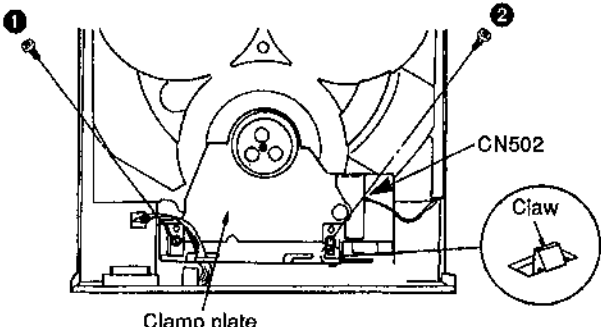
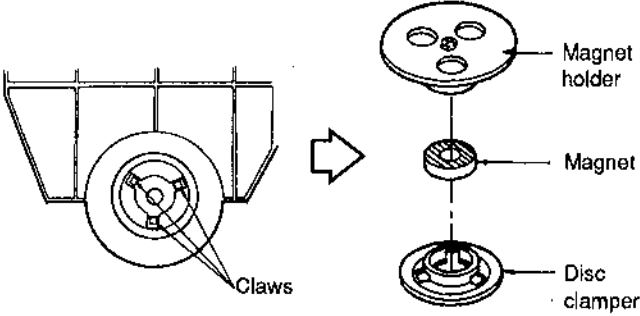
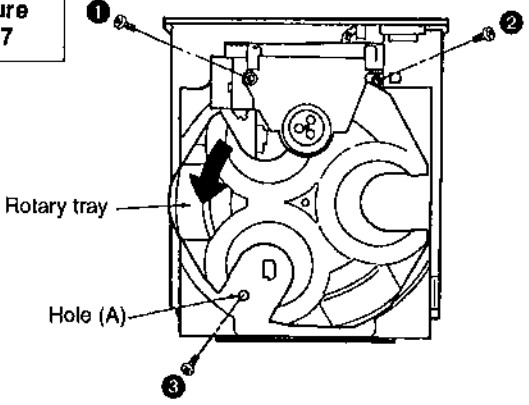
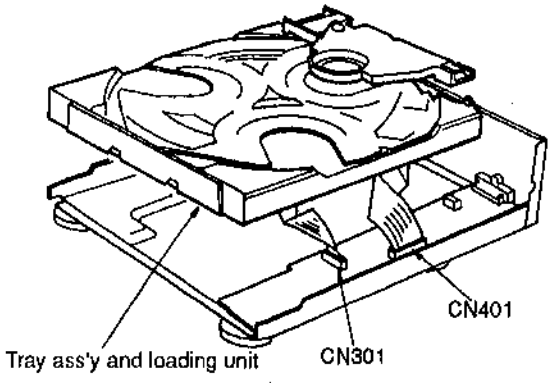
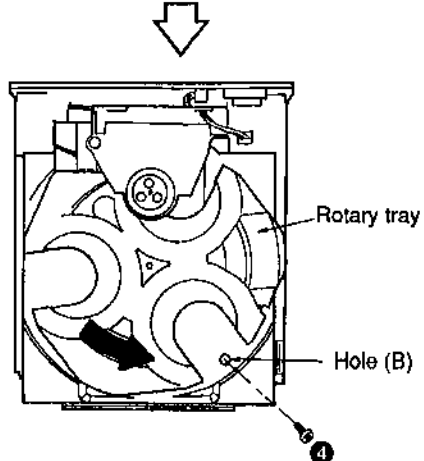
<p>Ref. No. 4</p>	<p>Removal of the LED P.C.B.</p>	<p>Ref. No. 5</p>	<p>Removal of the Clamp Plate</p>
<p>Procedure 1→4</p>		<p>Procedure 1→4→5</p>	
 <p>Claws</p> <p>LED P.C.B.</p> <p>• Release the 2 claws.</p>			 <p>1</p> <p>2</p> <p>CN502</p> <p>Clamp plate</p> <p>Claw</p> <p>1. Remove the 2 screws (1, 2). 2. Release the 1 claw.</p>
<p>Ref. No. 6</p>	<p>Removal of the Magnet Holder, Magnet and Disc Clamper</p>	<p>Ref. No. 7</p>	<p>Removal of the Tray Ass'y and Loading Unit</p>
<p>Procedure 1→4→5→6</p>		<p>Procedure 1→2→7</p>	
 <p>Claws</p> <p>Magnet holder</p> <p>Magnet</p> <p>Disc clamper</p> <p>• Release the 3 claws.</p>			 <p>1</p> <p>2</p> <p>Rotary tray</p> <p>Hole (A)</p> <p>3</p> <p>1. Remove the 2 screws (1, 2). 2. Rotate the rotary tray to the position that can be confirmed the hole (A). 3. Remove the 1 screw (3).</p> <p>Note: In case that screw 3 cannot be removed due to narrowness of hole (A), refer to the instruction of Ref.10, remove the tray base, and remove screw 3.</p>
 <p>Tray ass'y and loading unit</p> <p>CN301</p> <p>CN401</p> <p>6. Lift up the tray ass'y and the loading unit and then remove the 2 connectors (CN301, CN401).</p>			 <p>Rotary tray</p> <p>Hole (B)</p> <p>4</p> <p>4. Rotate the rotary tray to the further position that can be confirmed the hole (B). 5. Remove the 1 screw (4).</p>

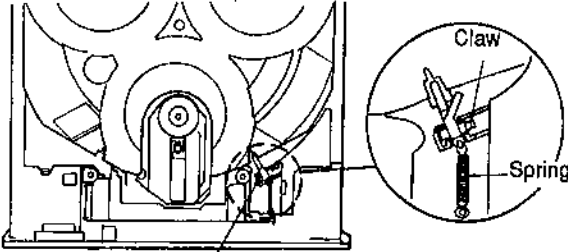
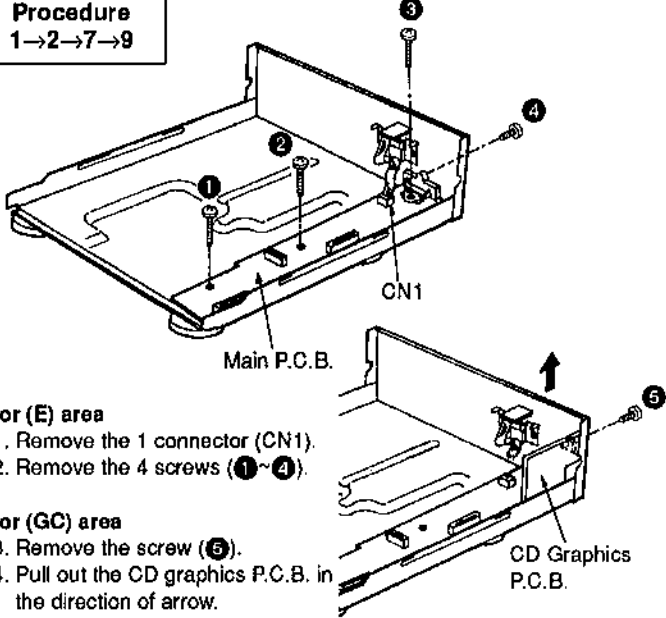
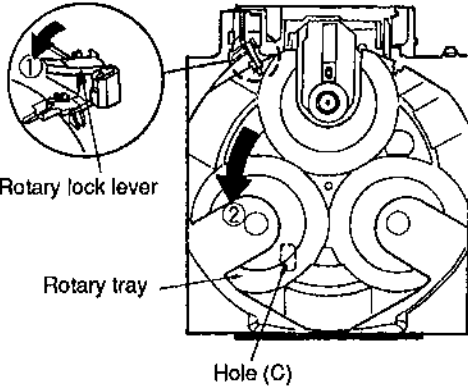
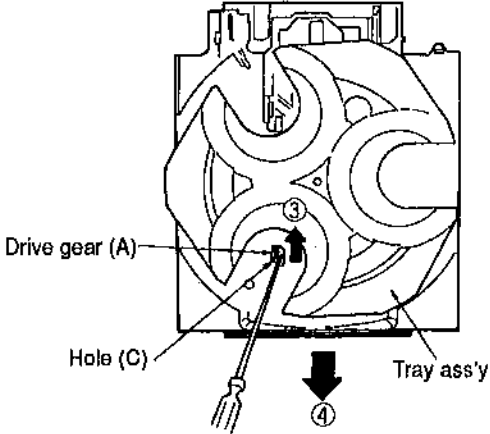
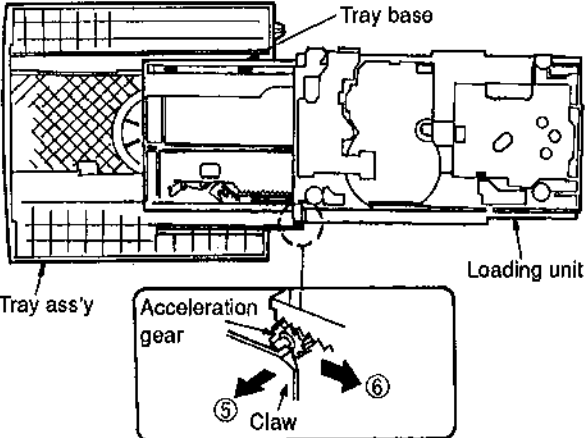
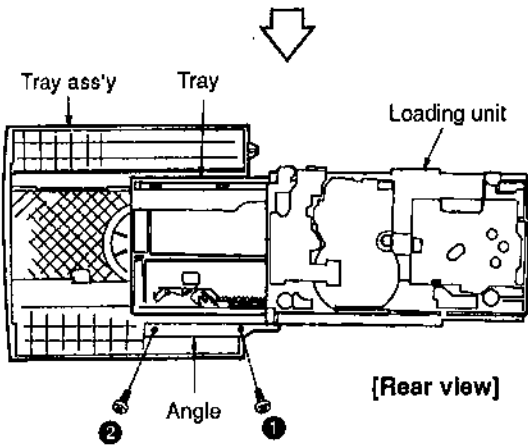
Ref. No. 8	Removal of the Rotary Lock Lever	Ref. No. 9	Removal of the Main P.C.B.
<p>Procedure 1→4→5→8</p>	 <p>Claw Spring Rotary lock lever</p> <ol style="list-style-type: none"> 1. Remove the spring. 2. Release the claw. 	<p>Procedure 1→2→7→9</p>	 <p>Main P.C.B. CN1 CD Graphics P.C.B.</p> <p>for (E) area 1. Remove the 1 connector (CN1). 2. Remove the 4 screws (①~④).</p> <p>for (GC) area 3. Remove the screw (⑤). 4. Pull out the CD graphics P.C.B. in the direction of arrow.</p>
<p>Ref. No. 10</p>	<p>Removal of the Loading Unit and Tray Base</p>		
<p>Procedure 1→2→4→5 →7→10</p>	 <p>Rotary lock lever Rotary tray Hole (C)</p> <ol style="list-style-type: none"> 1. While pressing the rotary lock lever in the direction of arrow ① and then rotate the rotary tray to the position that can be confirmed the hole (C) in the direction of arrow ②. 	 <p>Drive gear (A) Hole (C) Tray ass'y</p> <ol style="list-style-type: none"> 2. Pressing the drive gear (A) in the direction of arrow ③ with inserting the (-) screwdriver in the hole (C), the tray ass'y moves slightly in the direction of arrow ④. Then, pull the tray ass'y in the direction of arrow ④. 	
<p>Procedure</p>	 <p>Tray base Tray ass'y Loading unit Acceleration gear Claw</p> <ol style="list-style-type: none"> 5. Release the claw in the direction of arrow ⑤ and then remove the acceleration gear in the direction of arrow ⑥. 	 <p>Tray ass'y Tray Loading unit Angle</p> <p>[Rear view]</p> <ol style="list-style-type: none"> 1. Remove the 2 screws (①, ②). 2. Remove the angle. 	

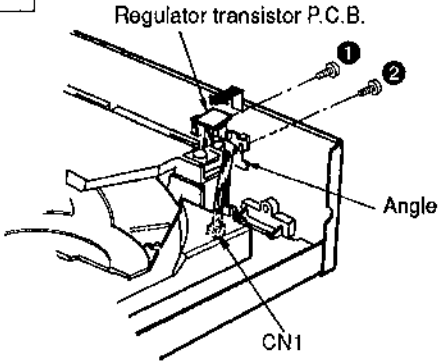
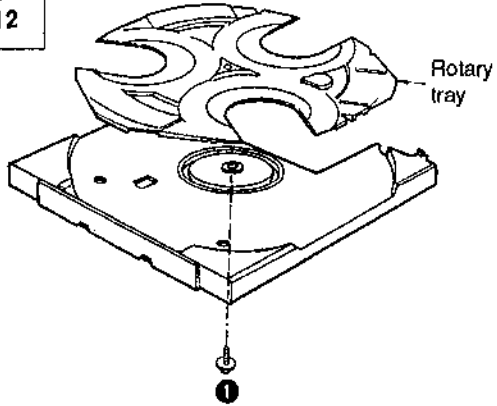
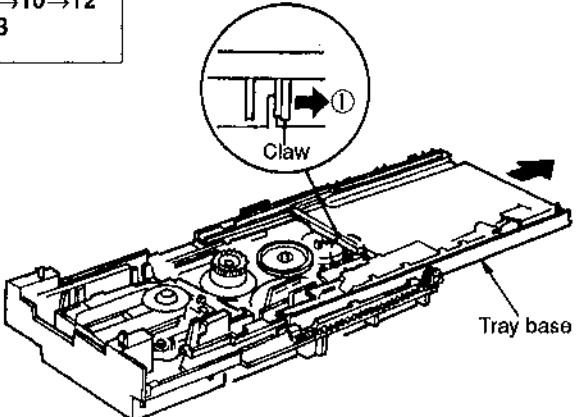
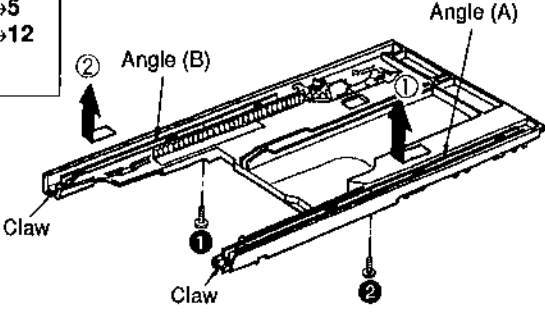
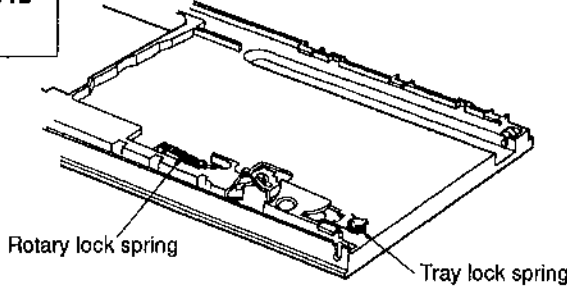
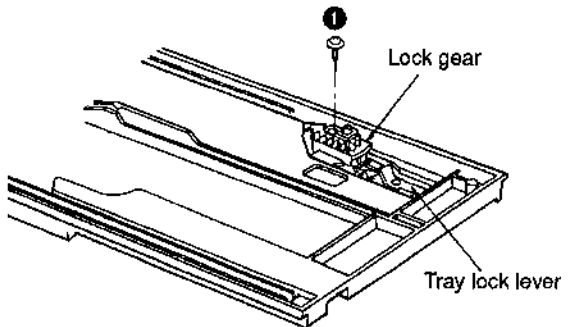
<p>Ref. No. 11</p>	<p>Removal of the Regulator Transistor P.C.B.</p>	<p>Ref. No. 12</p>	<p>Removal of the Rotary Tray</p>
<p>Procedure 1→11</p>	 <p>1. Remove the 1 connector (CN1). 2. Remove the 2 screws (1, 2). 3. Remove the angle in the direction of arrow.</p>	<p>Procedure 1→2→4→5 →7→10→12</p>	 <p>● Remove the 1 screw (1).</p>
<p>Ref. No. 13</p>	<p>Removal of the Tray Base</p>	<p>Ref. No. 14</p>	<p>Removal of the Angle (A) and Angle (B)</p>
<p>Procedure 1→2→4→5 →7→10→12 →13</p>	 <p>● Release the claw in the direction of arrow 1 and then remove the tray base in the direction of arrow 2.</p>	<p>Procedure 1→2→4→5 →7→10→12 →13→14</p>	 <p>■ Removal of the angle (A) 1. Remove the 1 screw (1). 2. Release the claw and then remove the angle (A) in the direction of arrow 1.</p> <p>■ Removal of the angle (B) 1. Remove the 1 screw (2). 2. Release the claw and then remove the angle (B) in the direction of arrow 2.</p>
<p>Ref. No. 15</p>	<p>Removal of the Tray Lock Lever and Lock Gear</p>		
<p>Procedure 1→2→4→5 →7→10→12 →13→15</p>	 <p>1. Remove the rotary lock spring and tray lock spring.</p>	 <p>2. Remove the 1 screw (1).</p>	

Ref. No. 16
Removal of the Traverse Deck and Conversion Lever

Procedure
1→2→4→5
→7→10→16

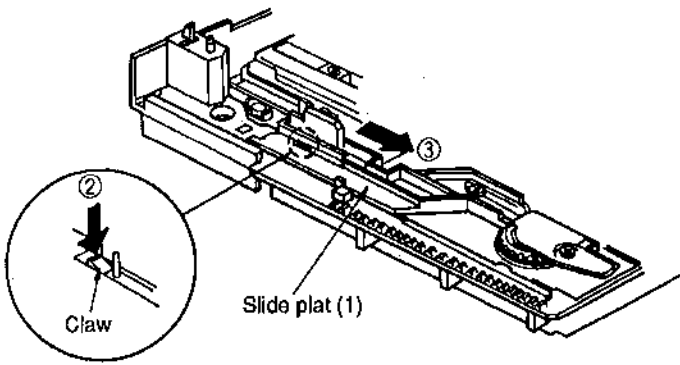
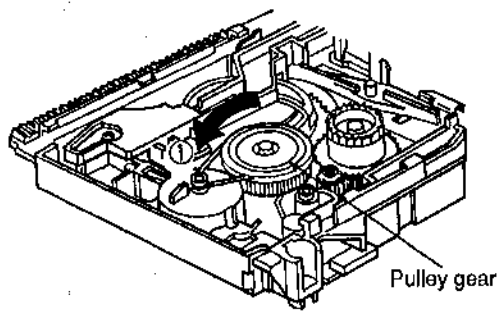

1. Rotate the pulley gear to full position in the direction of arrow ①.

2. Push the claw in the direction of arrow ②, and then move the slide plate (1) in the direction of arrow ③.

Ref. No. 17
Removal of the Slide Plate (1)

Procedure
1→2→4→5
→7→10→16
→17

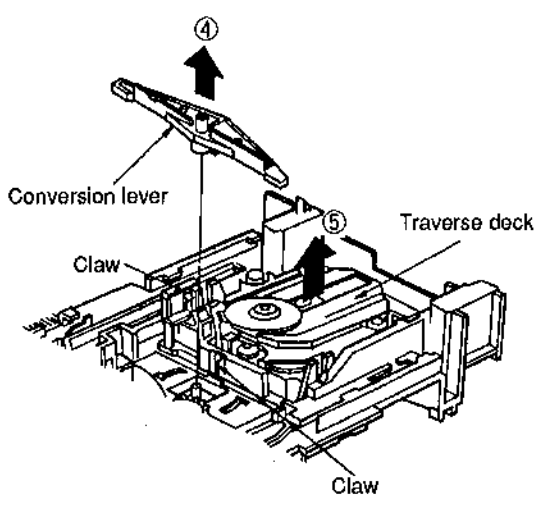
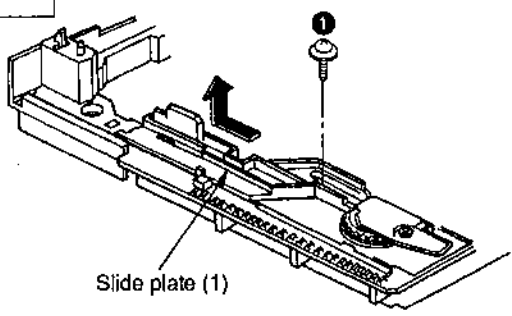

1. Remove the 1 screw (①).
2. Remove the slide plate (1) in the direction of arrow.

3. Remove the conversion lever in the direction of arrow ④.
4. Release the claw and then remove the traverse deck in the direction of arrow ⑤.

Ref. No. 18
Removal of the Slide Plate (3)

Procedure
1→2→4→5
→7→10→16
→18

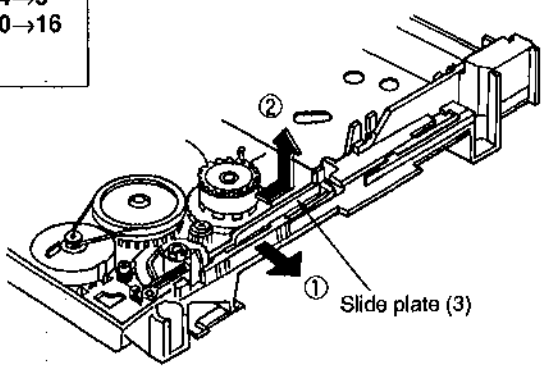

Ref. No. 19
Removal of the Slide Plate (2)

Procedure
1→2→4→5
→7→10→16
→18→19

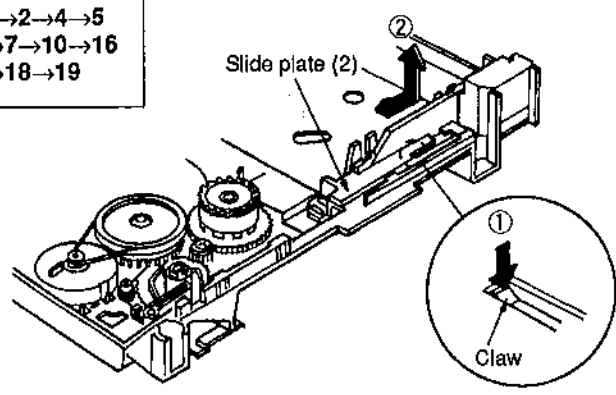

• Push the slide plate (3) in the direction of arrow ①, and then remove it in the direction of arrow ②.

• Push the claw in the direction of arrow ①, and then remove the slide plate (2) in the direction of arrow ②.

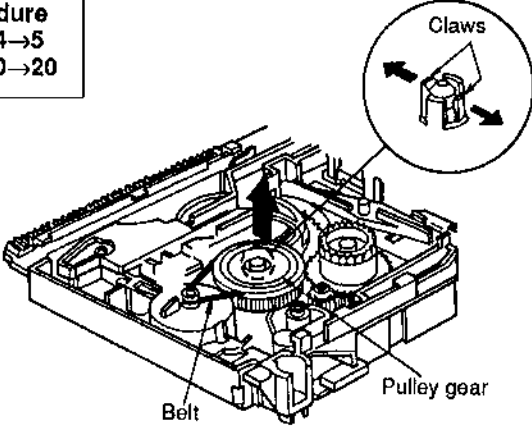
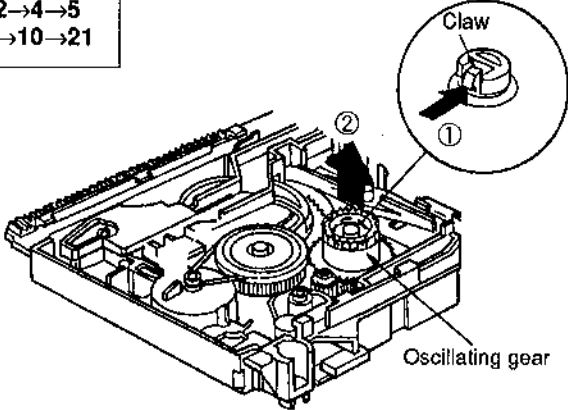
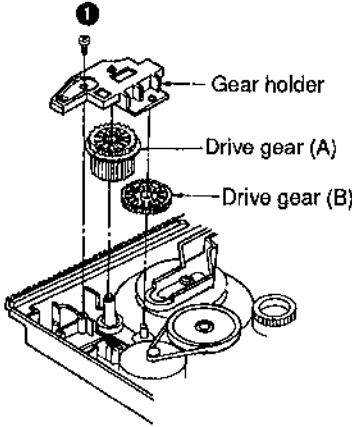
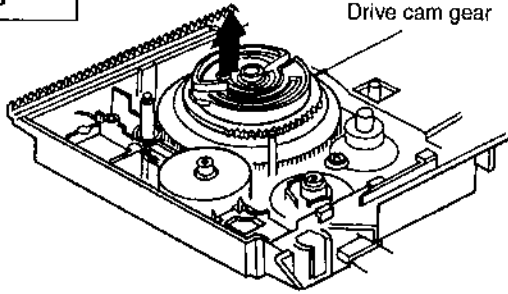
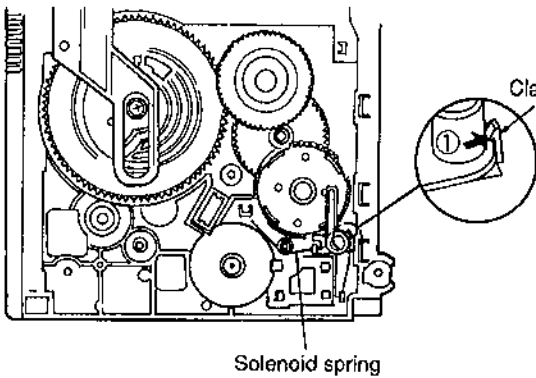
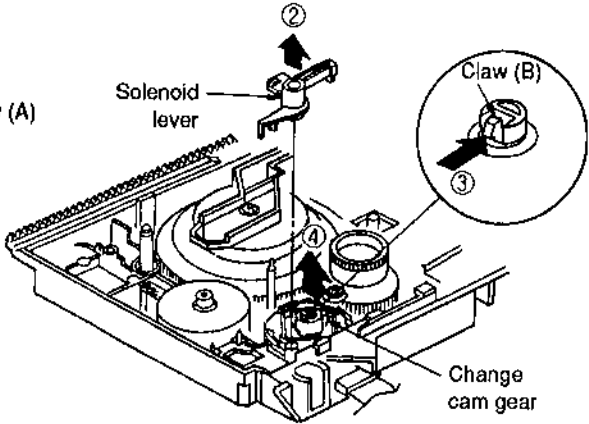
<p>Ref. No. 20</p>	<p>Removal of the Pulley Gear</p>	<p>Ref. No. 21</p>	<p>Removal of the Oscillating Gear</p>
<p>Procedure 1→2→4→5 →7→10→20</p>	 <p>1. Remove the belt. 2. Release the 2 claws and then remove the pulley gear in the direction of arrow.</p>	<p>Procedure 1→2→4→5 →7→10→21</p>	 <p>• Release the claw in the direction of arrow ① and then remove the oscillating gear in the direction of arrow ②.</p>
<p>Ref. No. 22</p>	<p>Removal of the Gear Holder, Drive Gear (A) and Drive Gear (B)</p>	<p>Ref. No. 23</p>	<p>Removal of the Drive Cam Gear</p>
<p>Procedure 1→2→4→5 →7→10→22</p>	 <p>1. Remove the 1 screw (①). 2. Remove the gear holder, drive gear (A) and drive gear (B).</p>	<p>Procedure 1→2→4→5 →7→10→16 →17→20→21 →22→23</p>	 <p>• Remove the drive cam gear in the direction of arrow.</p>
<p>Ref. No. 24</p>	<p>Removal of the Change Cam Gear</p>		
<p>Procedure 1→2→4→5 →7→10→16 →18→20→24</p>	 <p>1. Remove the solenoid spring. 2. Release the claw (A) in the direction of arrow ① and then remove the solenoid lever in the direction of arrow ②.</p>		 <p>3. Release the claw in the direction of arrow ③ and then remove the change cam gear in the direction of arrow ④.</p>

Ref. No. 25 **Removal of the Reduction Gear and Gear Lever**

Procedure
 1→2→4→5
 →7→10→16
 →17→18→20
 →21→22→23
 →24→25

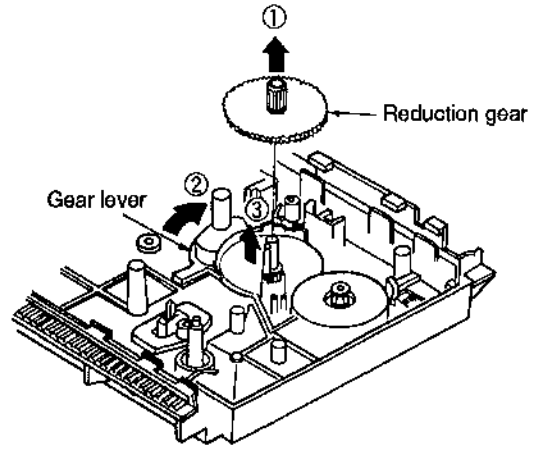
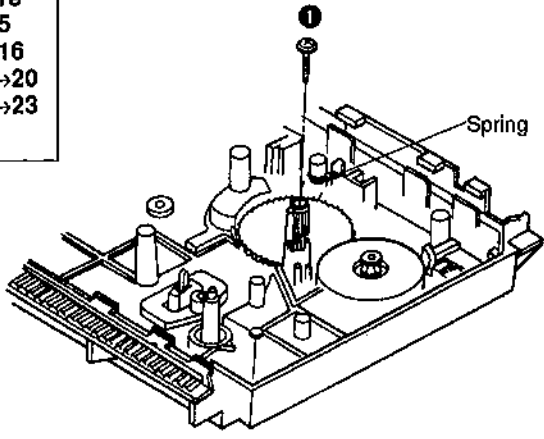

1. Remove the spring.
2. Remove the 1 screw (1).

3. Remove the reduction gear in the direction of arrow ①.
4. Turn the gear lever in the direction of arrow ②, and then remove it in the direction of arrow ③.

Ref. No. 26 **Removal of the Loading Motor P.C.B.**

Procedure
 1→2→4→5
 →7→10→16
 →17→18→19
 →20→21→22
 →23→24→26

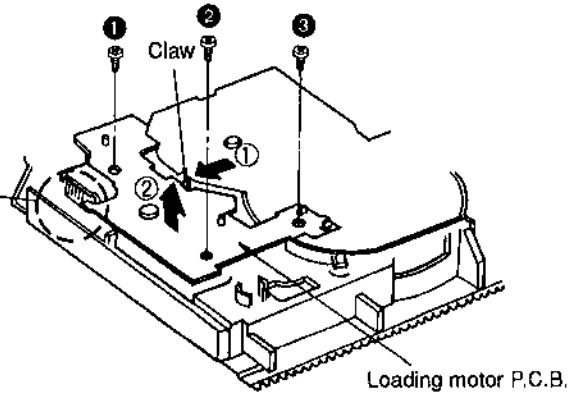
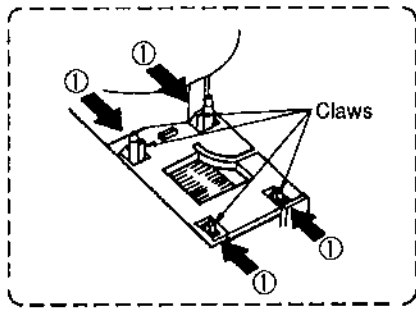

1. Remove the 3 screws (1~3).
2. Release the 5 claws in the direction of arrow ①.

3. Remove the loading motor P.C.B. in the direction of arrow ②.

Ref. No. 27 **Removal of the Loading Motor**

Procedure
 1→2→4→5
 →7→10→16
 →17→18→19
 →20→21→22
 →23→24→26
 →27

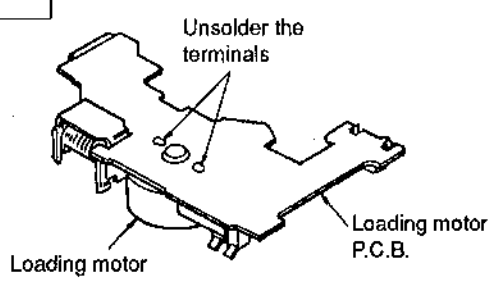
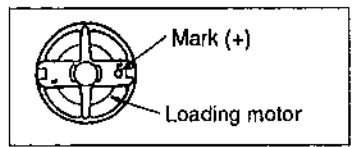

•Unsolder the terminals of the loading motor.

Ref. No. 28 **Removal of the Photo Transistor P.C.B.**

Procedure
 1→2→4→5
 →7→28

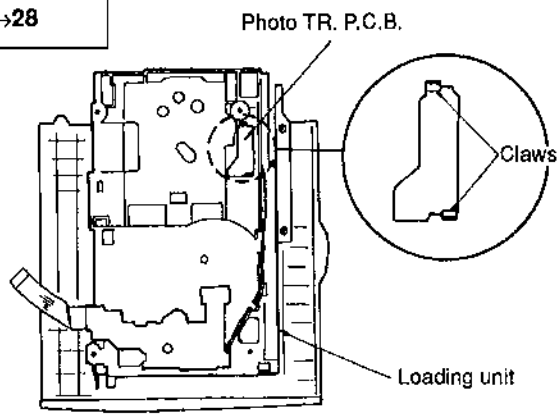

•Release the 2 claws.

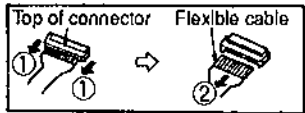
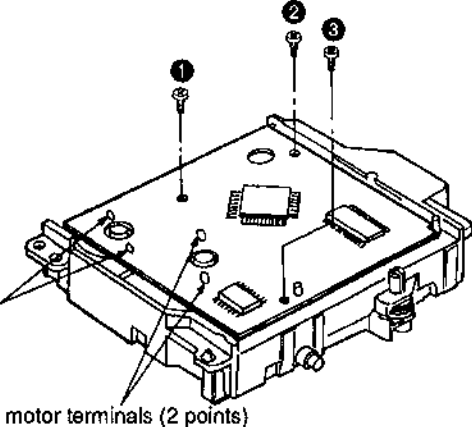
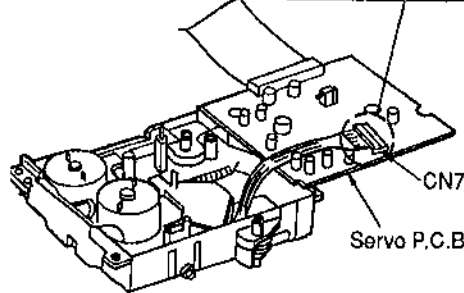
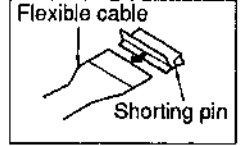
<p>Ref. No. 29</p>	<p>Removal of the Servo P.C.B.</p>	<p>※ Push the top of the connector in the direction of arrow ①, and then pull out the flexible cable in the direction of arrow ②.</p> 
<p>Procedure 1→2→4→5 →7→10→16 →29</p>	 <p>Traverse motor terminals (2 points) Spindle motor terminals (2 points)</p> <ol style="list-style-type: none"> 1. Remove the 3 screws (①~③). 2. Unsolder the spindle motor terminals (2 points). 3. Unsolder the traverse motor terminals (2 points). 	 <p>CN701 Servo P.C.B.</p> <p>4. Remove the connector (CN701).</p> <p>Note: Insert a shorting pin into the traverse unit flexible cable. (Refer to "handling precautions for traverse deck" on page 2.)</p> 

● Replacement of the Foot

1. Remove the 4 heat melted posts on the Bottom board ass'y with a pair of nippers or similar tool.
2. To replace the foot (RKA0011-3) on the Bottom board ass'y, melt the 4 posts with a soldering iron.

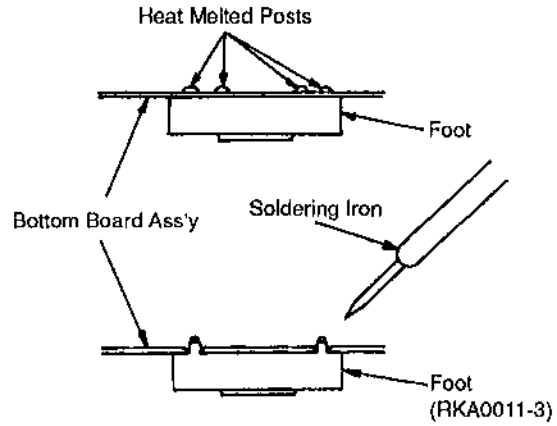

● Installing Servo P.C.B.

1. Before installing the servo P.C.B., move the optical pickup toward the outer edge from the mark "▼".
[Otherwise, the rest detect switch (S701) mounted on the servo P.C.B. may be damaged.]
2. Connect the flexible cable to the connector (CN701).
3. Install the servo P.C.B. in the traverse deck unit with the three screws.
4. Solder the two terminals of the traverse motor and the two terminals of the spindle motor.

Note: Connect the flexible cable to the connector (CN701) firmly.
Tighten the 3 screws before soldering the terminals.

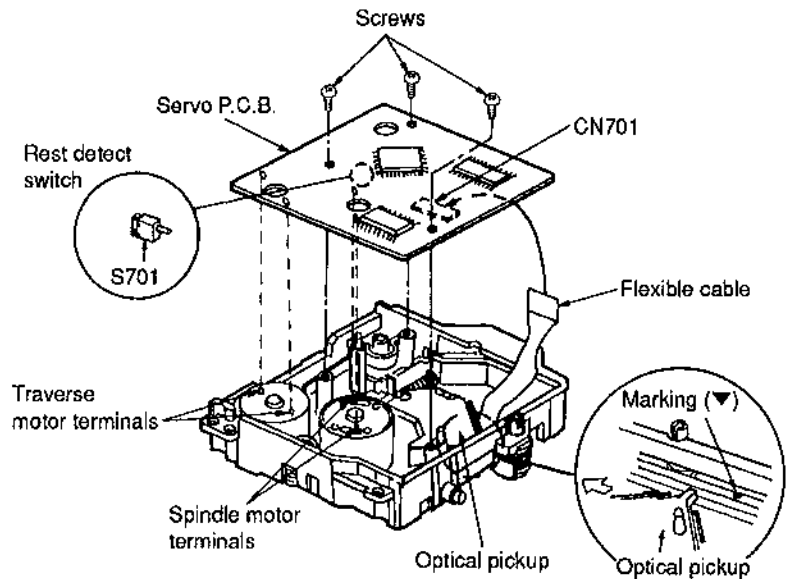

■ How to Check the Servo and Main P.C.B.

● Check the servo P.C.B.

1. Remove the cabinet. (See Ref.No.1 of the disassembly instructions.)
2. Remove the front panel ass'y. (See Ref.No.2 of the disassembly instructions.)
Note: Take care not to remove the connector (CN603).
3. Remove the clamp plate. (See Ref.No.5 of the disassembly instructions.)
4. Remove the magnet holder, magnet and disc clamber. (See Ref.No.6 of the disassembly instructions.)

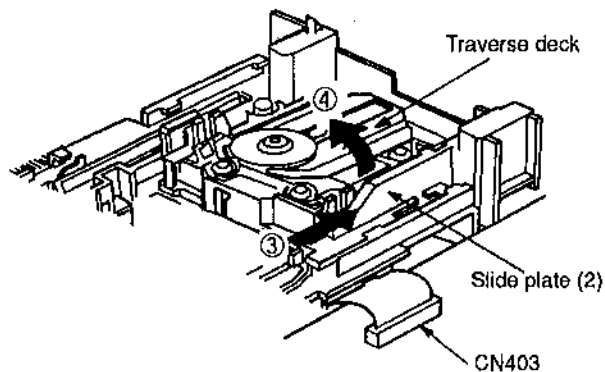
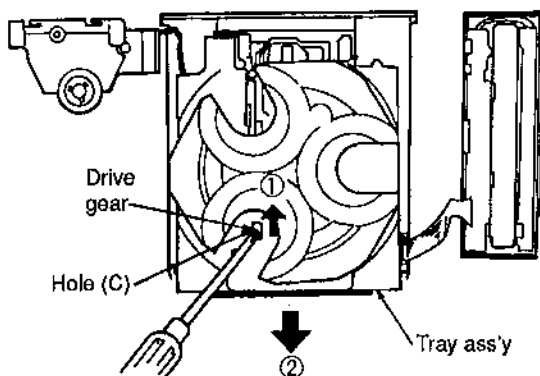

5. Pressing the lock gear in the direction of arrow ① with inserting the (-) screwdriver in the hole (C), the tray ass'y moves slightly in the direction of arrow ②. Then, pull out the tray ass'y in the direction of arrow ②.

6. Remove the connector (CN403).
7. Pressing the slide plate (2) in the direction of arrow ③, and then remove the traverse deck in the direction of arrow ④.

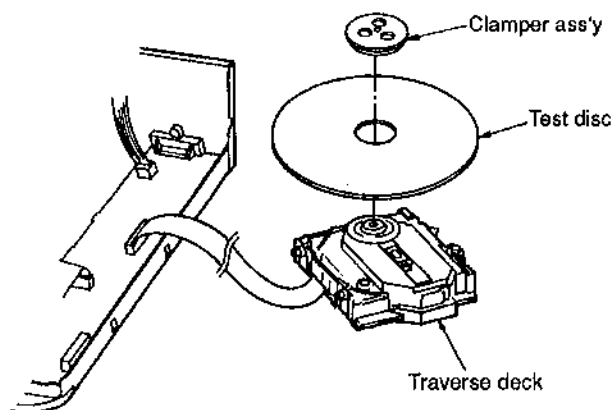
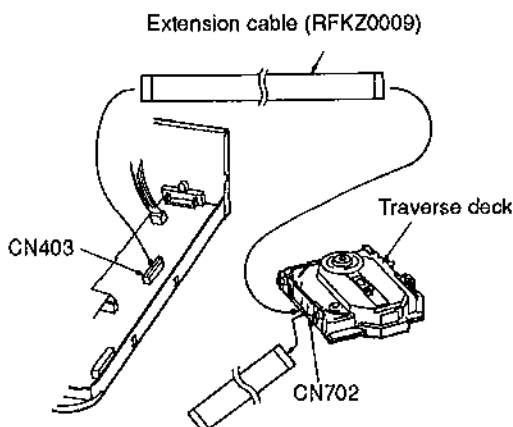

8. Substitute the serviceable extension cable for the F.P.C. between the connector (CN403) on main P.C.B. and the connector (CN702) on servo P.C.B..

9. Place the test disc and secure it by using the clamber ass'y.

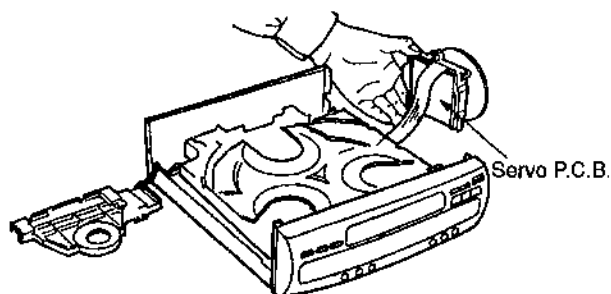
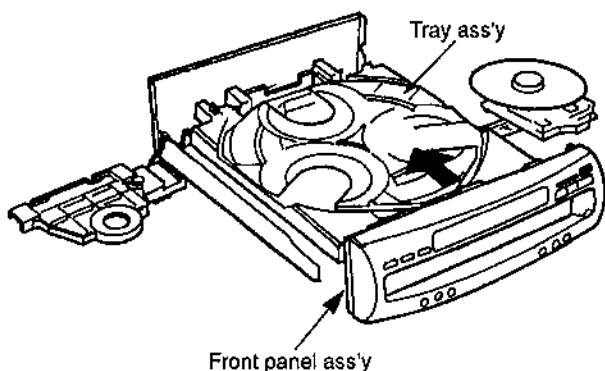

10. Restore the tray ass'y in the direction of arrow ⑤.
11. Reinstall the front panel ass'y to the main unit.

12. When checking the soldered surface of the servo P.C.B., do as shown above.

• Check the main P.C.B.

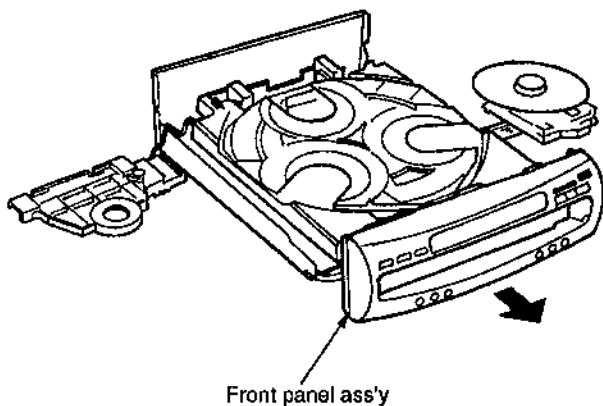

1. After checking the servo P.C.B., remove the front panel ass'y in the direction of arrow.

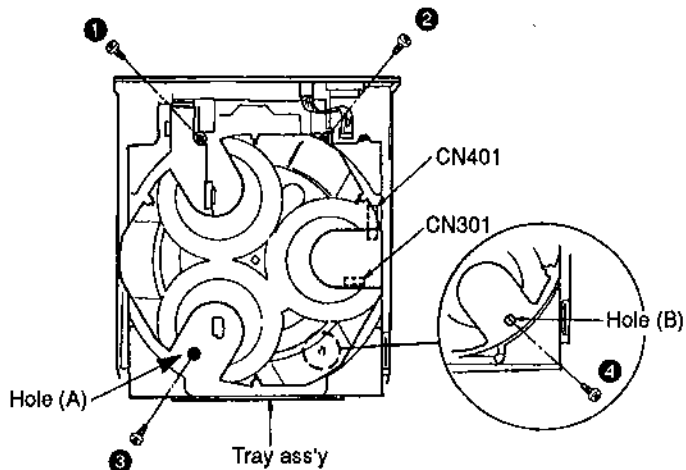

2. Remove the 4 screws (1~4) and then remove the tray ass'y.

3. Remove the 2 connector (CN301, CN401).

Note:

In case that screw 3 cannot be removed due to narrowness of hole (A), refer to the Disassembly Instruction Ref.No.10 and remove the tray base and screw 3.

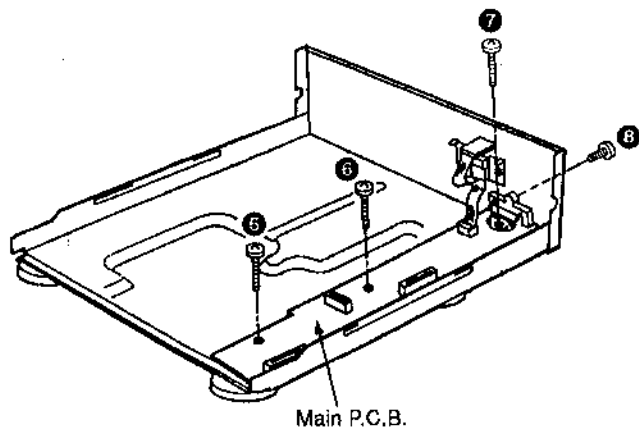

4. Remove the 4 screws (5~8).

5. Remove the main P.C.B..

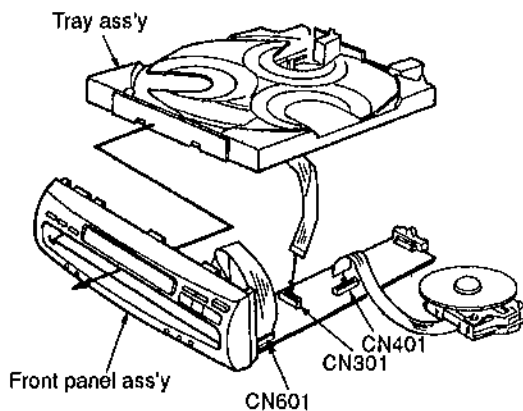

6. Reinstall the front panel ass'y to main P.C.B..

7. Reinstall the tray ass'y to front panel ass'y.

8. Connect the 3 F.P.C. board (CN301, CN401, CN601).

■ Installation of the Loading Components

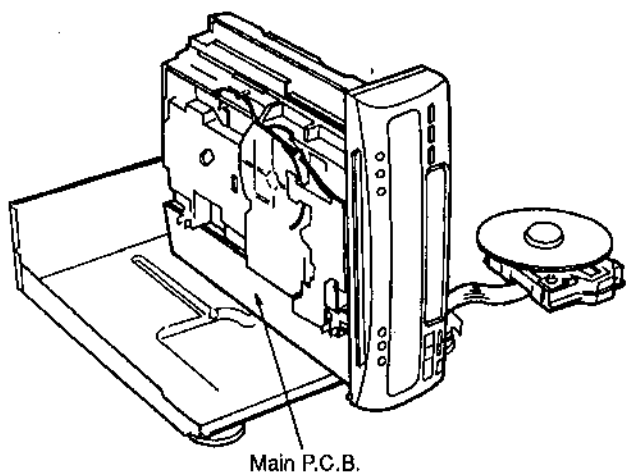

9. When checking the soldered surface of the main P.C.B., do as shown above.

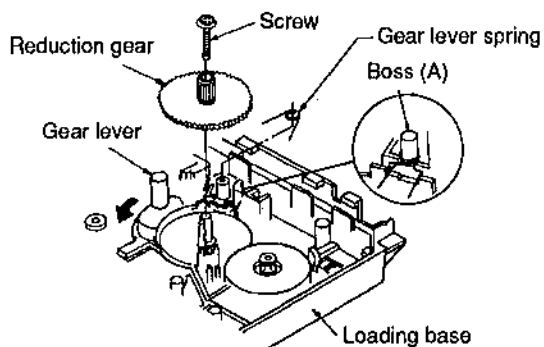

Fig.1

1. Install the gear lever on the loading base and then slide the gear lever in the direction of arrow ①. (See Fig.1.)

2. Install the reduction gear and secure it with a screw. (See Fig.1.)

3. Install the gear lever spring to the boss (A). (See Fig.1.)

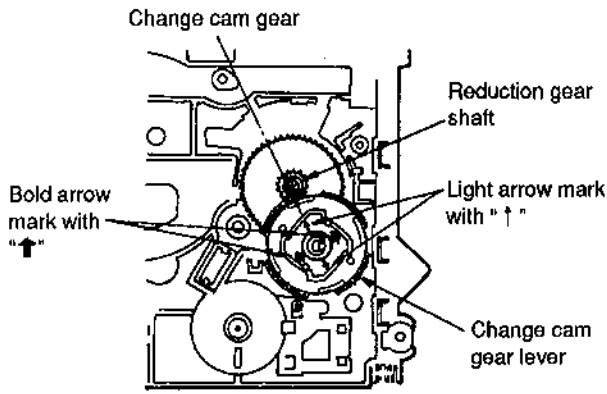

Fig.2

4. Install the change cam gear. (See Fig.2.)
Note: Align the tip of the light arrow marked with "↑" on the change cam gear with the axis of the reduction gear shaft.

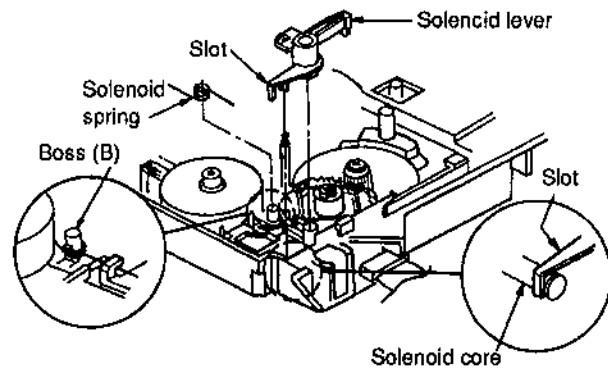

Fig.3

5. Install the solenoid lever. (See Fig.3)
Note: Align the slot of the solenoid lever with the solenoid core.
 6. Install the solenoid spring to the boss (B). (See Fig.3.)

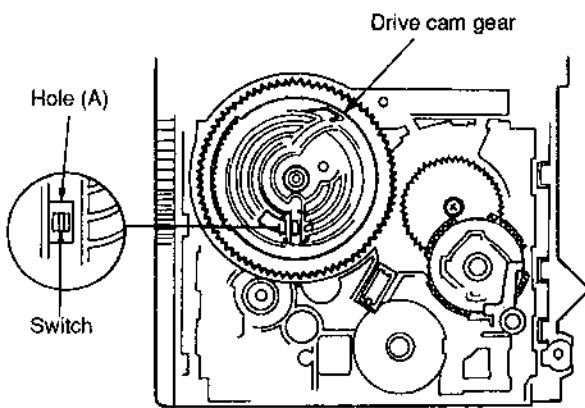

Fig.4

7. Align the hole (A) of the drive cam gear with the switch, and then insert the drive cam gear. (See Fig. 4)
Note: In case that the drive cam gear is inserted into the holes except the hole (A) of the drive cam gear, the switch may be damaged.

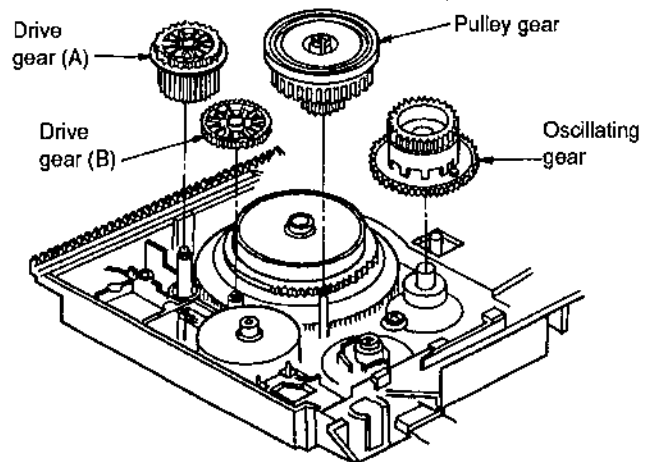

Fig.5

8. Install the drive gear (B), the drive gear (A), the oscillating gear ass'y and the pulley gear. (See Fig. 5)

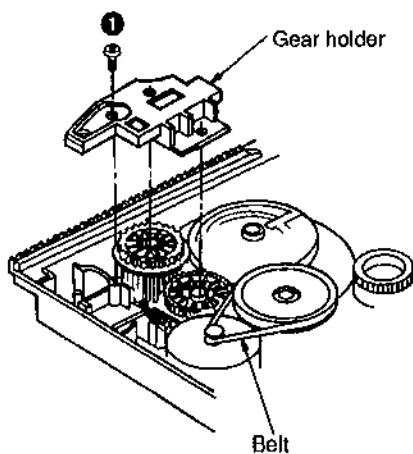

Fig.6

9. Install the gear holder and secure it with a screw ①. (See Fig.6.)
 10. Install the belt. (See Fig.6.)

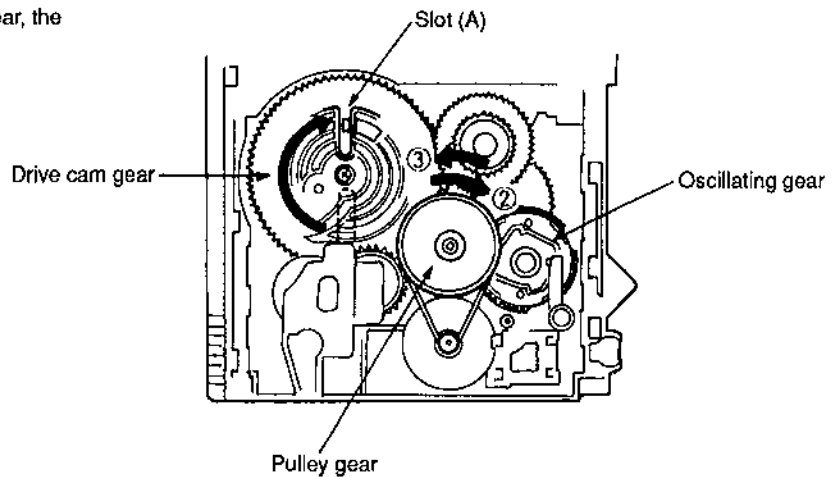

Fig.7

11. Rotate the pulley gear in the direction of arrow ② and then rotate the pulley gear to full position in the direction of arrow ③ when the oscillating gear stops.
 12. Rotate the drive cam gear so that the slot (A) of the drive cam gear is put into a given position as shown in fig.7.

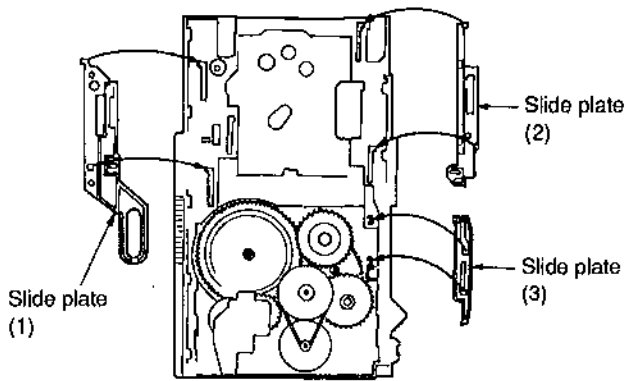

Fig.8

13. Install slide plate (1), slide plate (2) and slide plate (3).

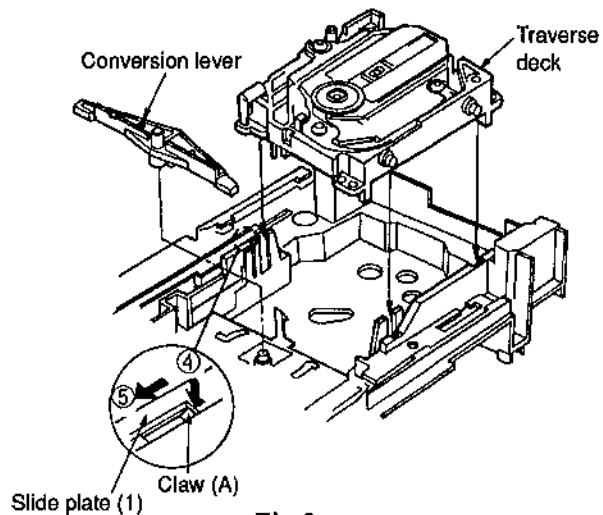

Fig.9

14. Press catch (A) in the direction of arrow ④ and then push slide (1) of the loading unit in the direction of arrow ⑤. (See Fig.9)
15. Install the traverse deck and the conversion lever. (See Fig.9)

■ Installation of the Tray Base and the Tray Ass'y

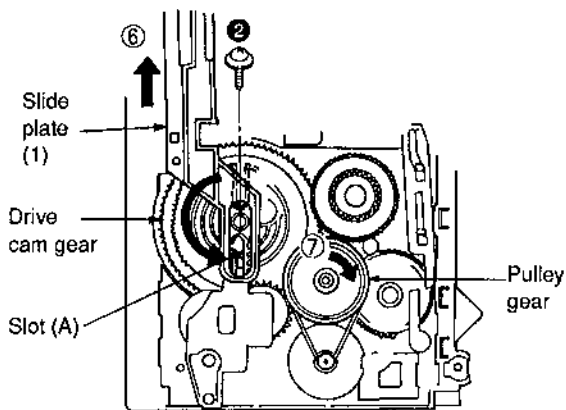

Fig.10

16. Push slide plate (1) in the direction of arrow ⑥, so that the catch (A) in Fig.9 engages with slide plate (1).
17. Secure slide plate (1) with a screw ②.
18. Rotate the pulley gear in the direction of arrow ⑦ so that slot (A) of the drive cam gear is in the position shown in Fig.10.

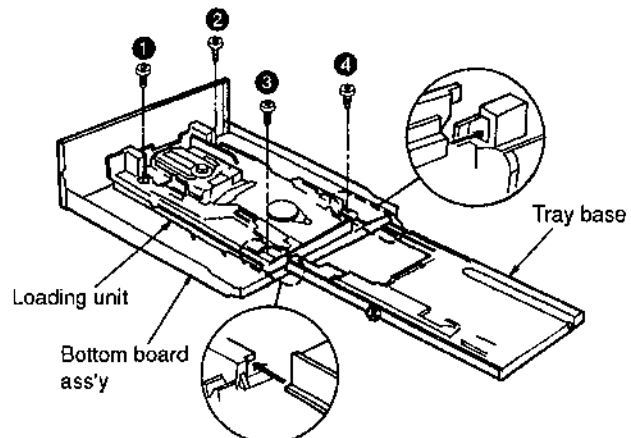

Fig.1

1. Install the loading unit on the bottom board ass'y and secure it with 4 screws ①~④. (See Fig.1)
2. Install the tray base on the loading unit. (See Fig.1)

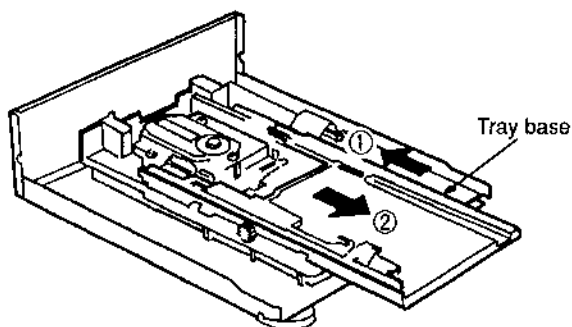

Fig.2

3. After sliding the tray base in the direction of arrow ①, draw the tray base gradually in the direction of arrow ②. (See Fig.2)
Slide the tray base until the tray base stops.

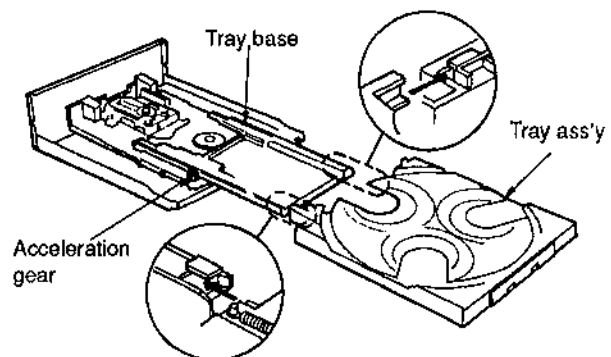
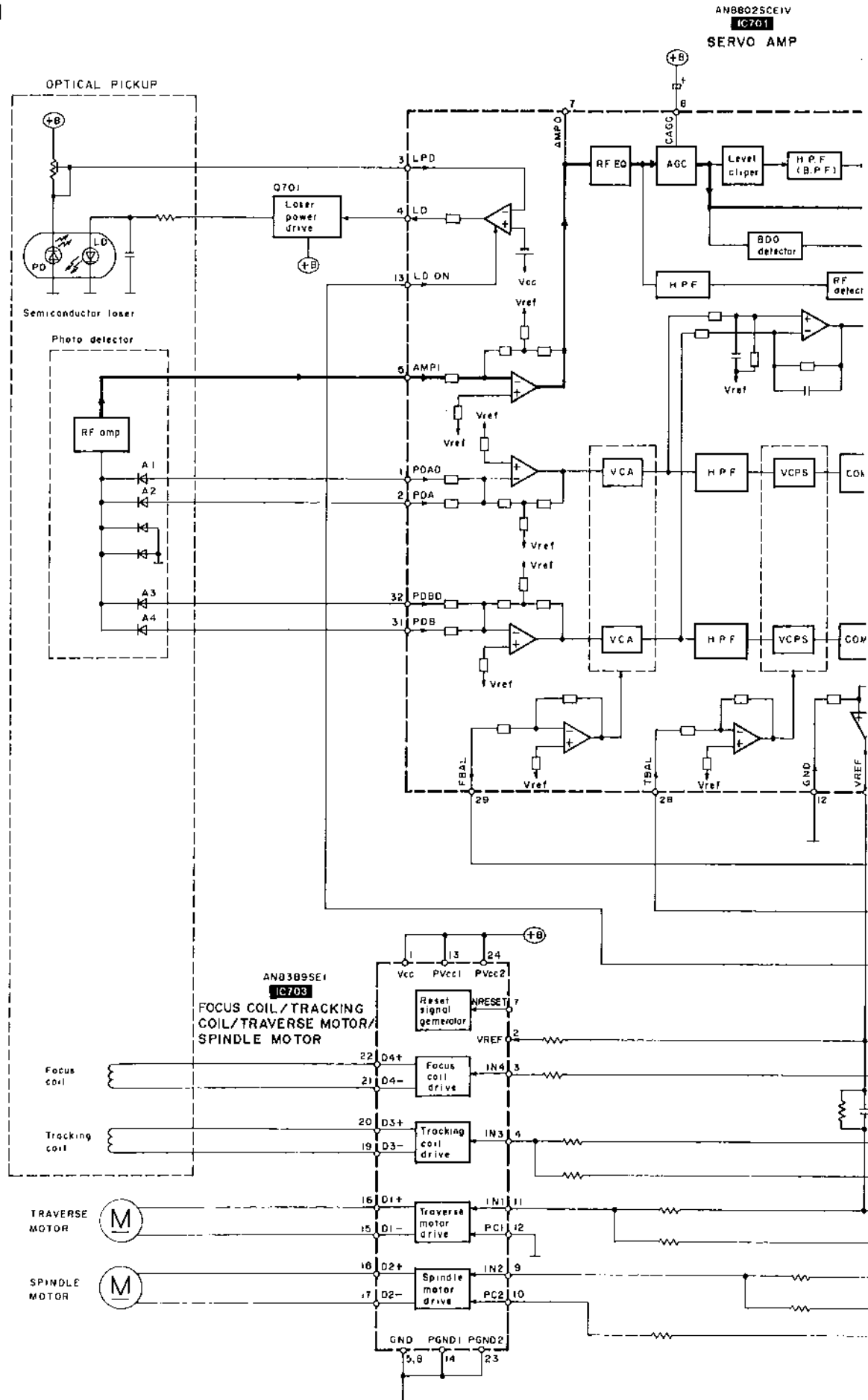
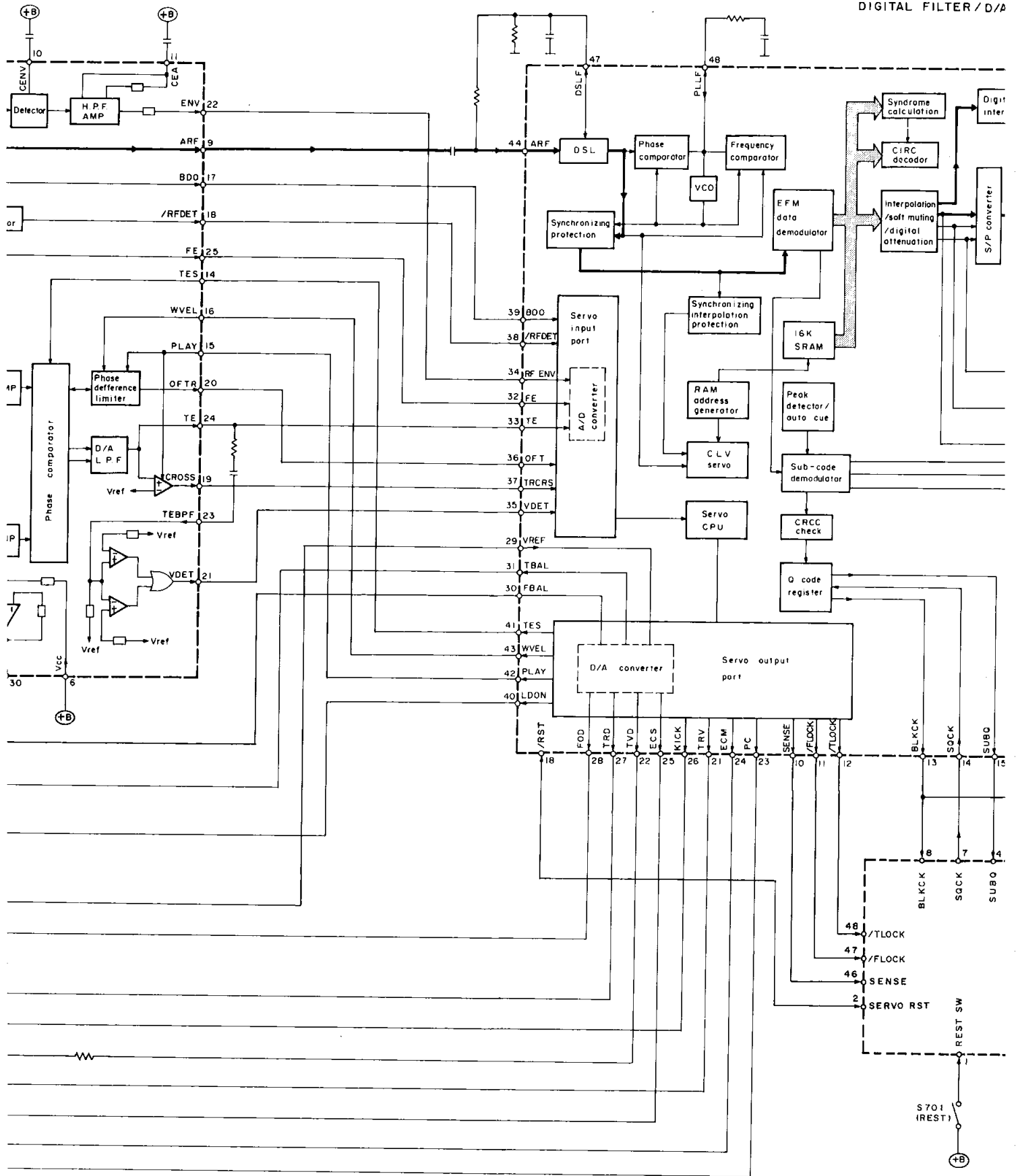

Fig.3

4. Holding the tray base, install the tray ass'y on the tray base and feed the tray ass'y slowly. (See Fig.3)
5. After engaging the acceleration gear, release the tray base which is held and feed the tray ass'y. (See Fig.3)

Block Diagram





N66271RA

IC702

DIGITAL SIGNAL PROCESSOR / CONVERTER

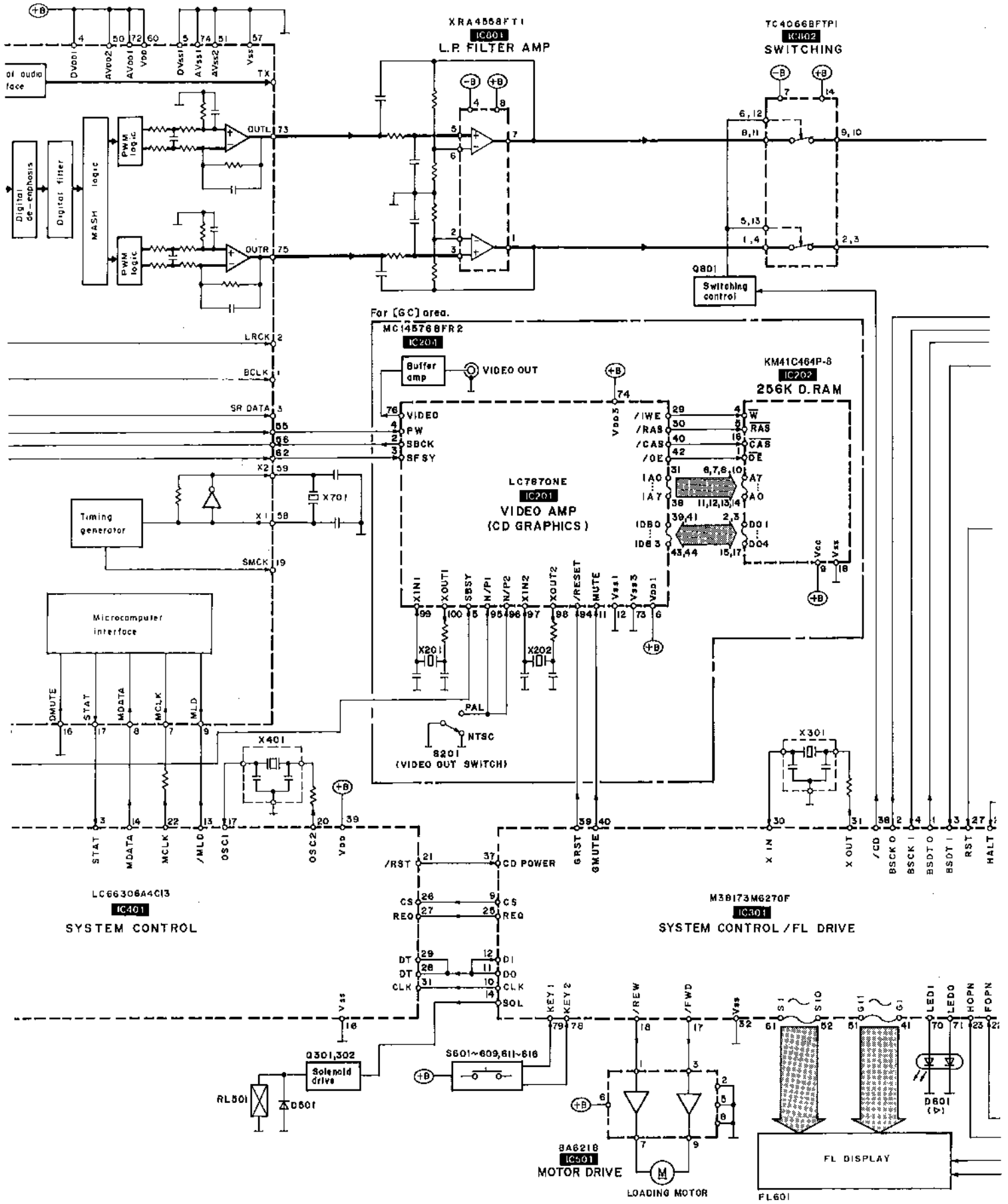

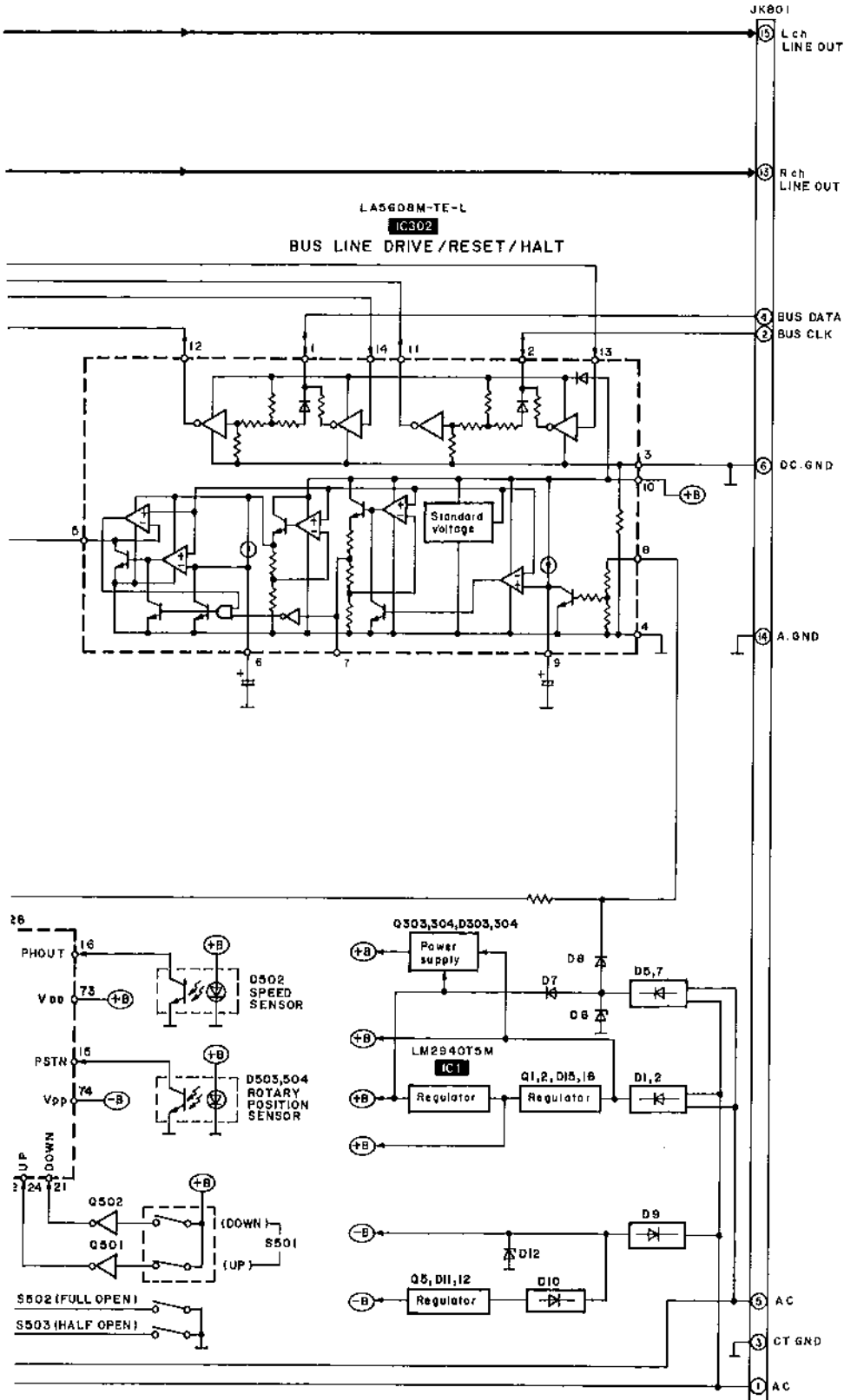

■ Schematic Diagram ● Optical Pickup/Servo Circuit (Parts list on page 54~57)

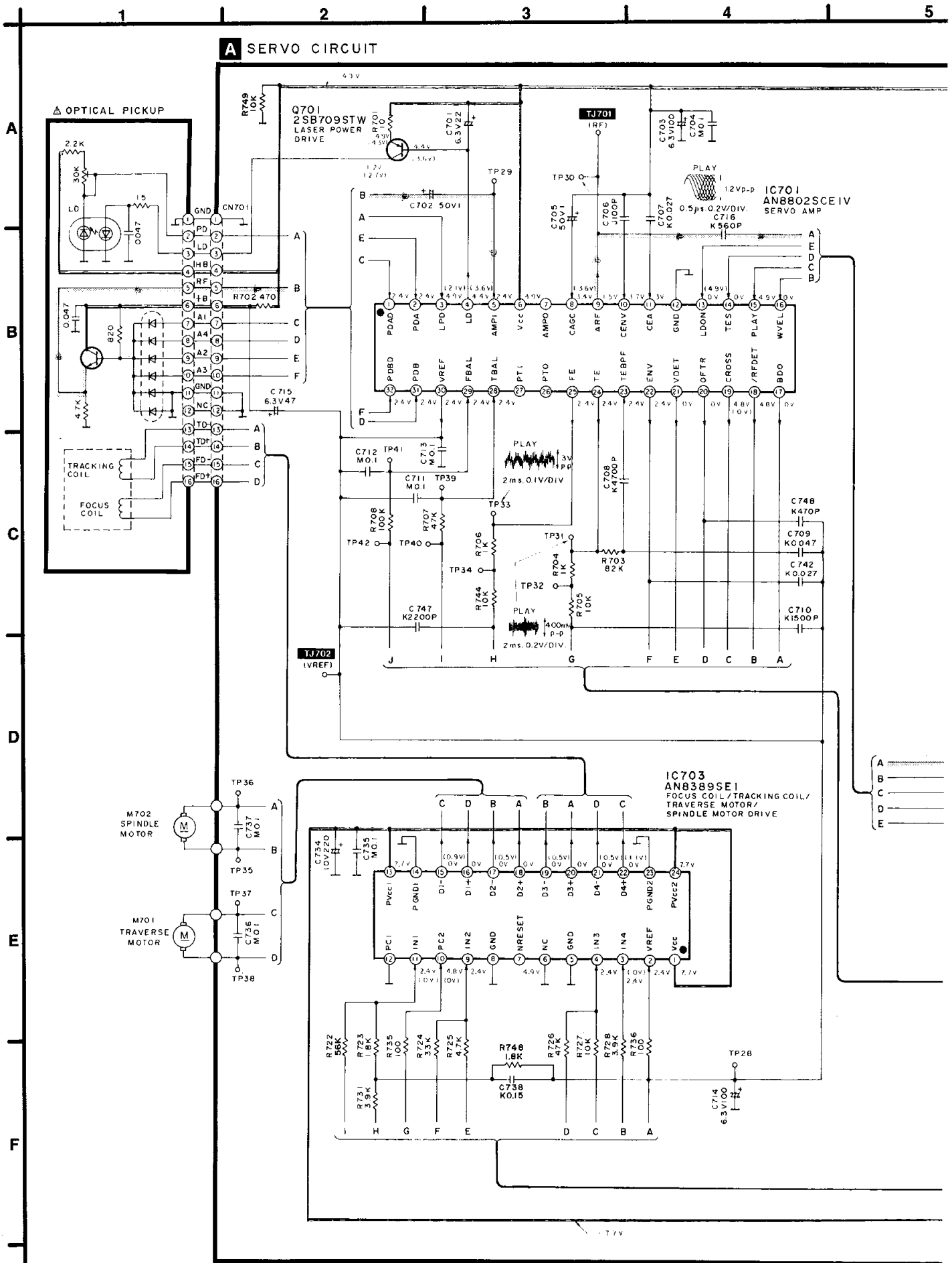

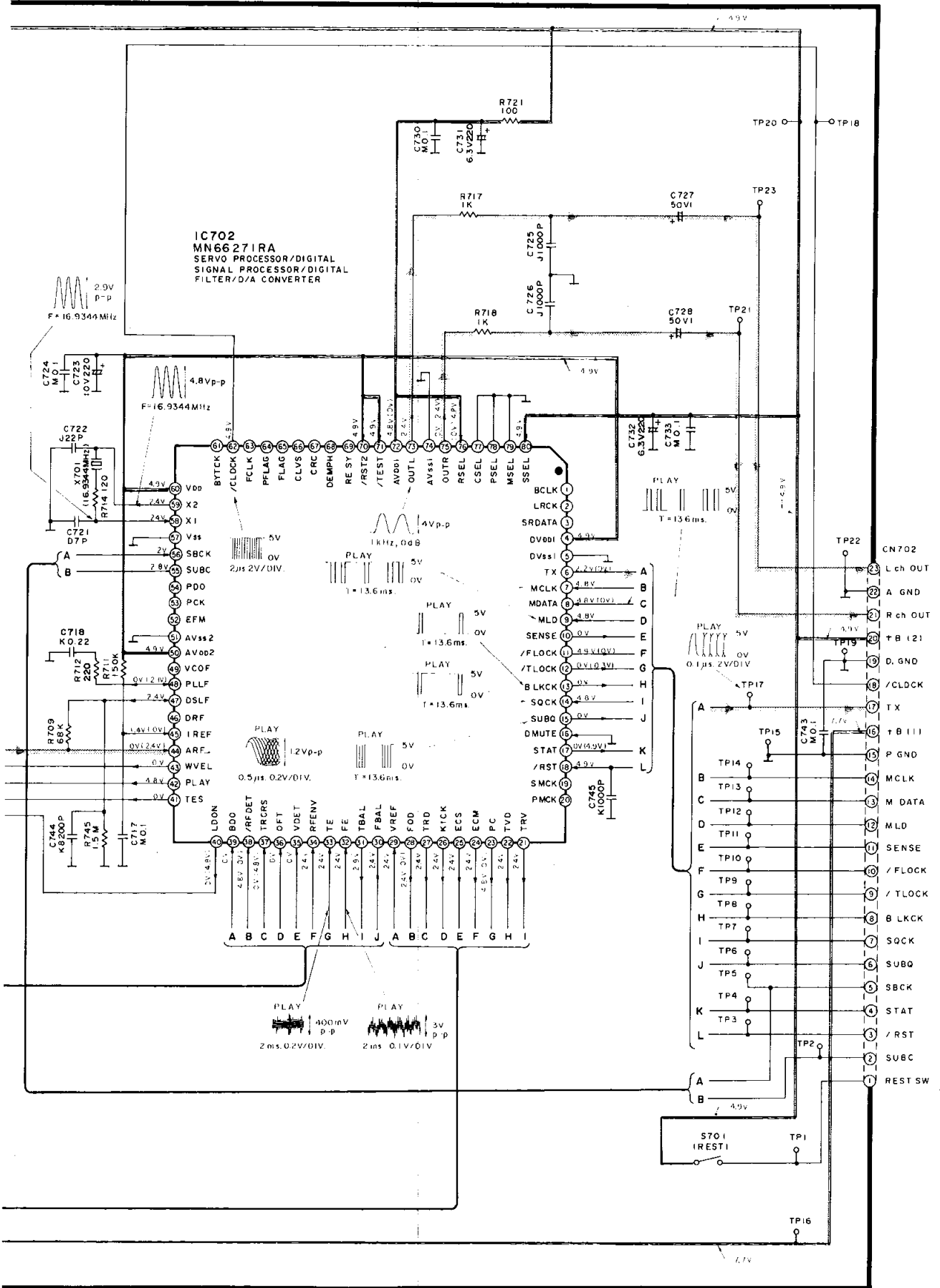

To **G** MAIN CIRCUIT (CN401) (Page 29)

●CD Graphics Circuit (Parts list on page 54~57)

1 CD GRAPHICS CIRCUIT For [GC] area.

A

B

C

D

E

F

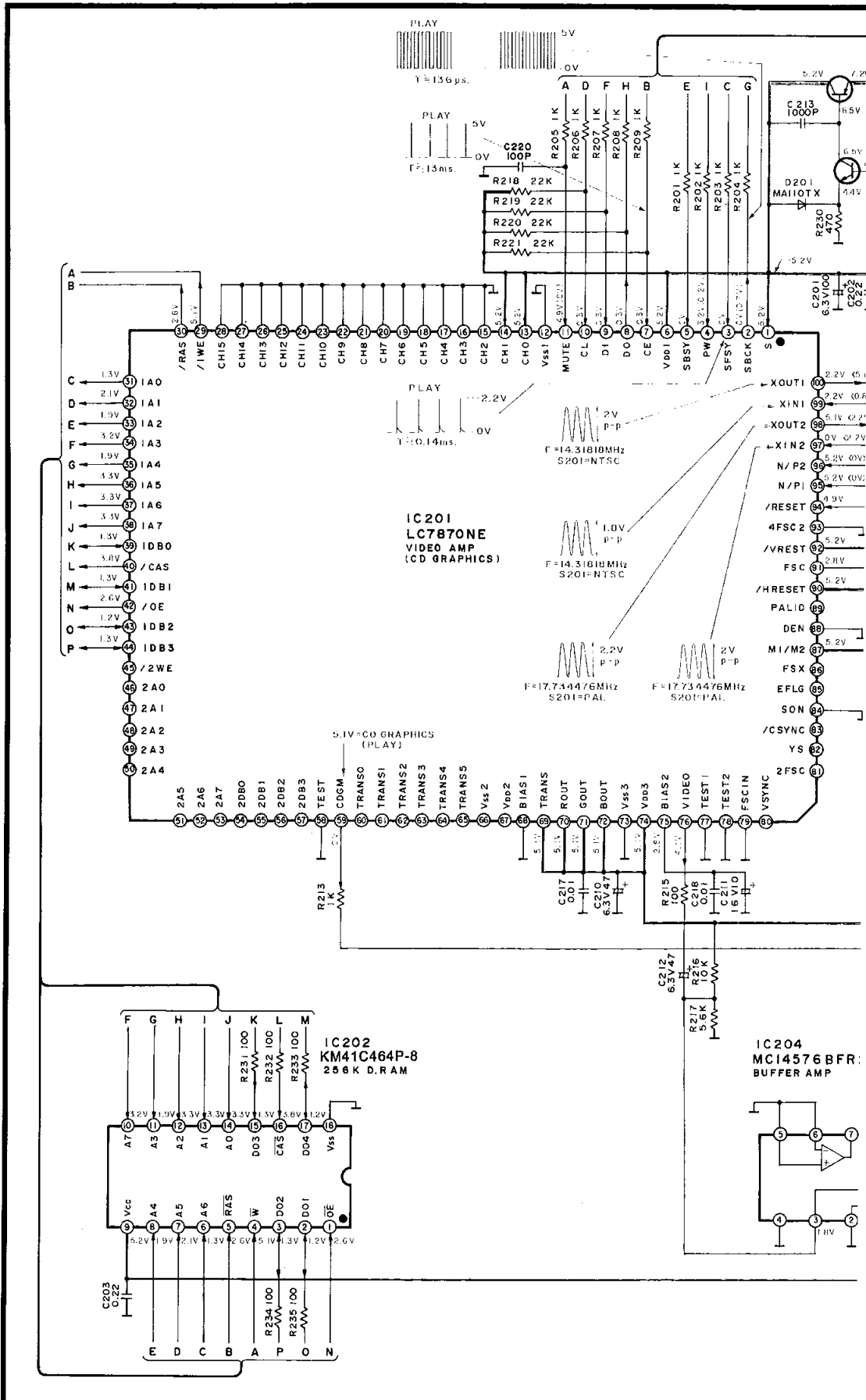

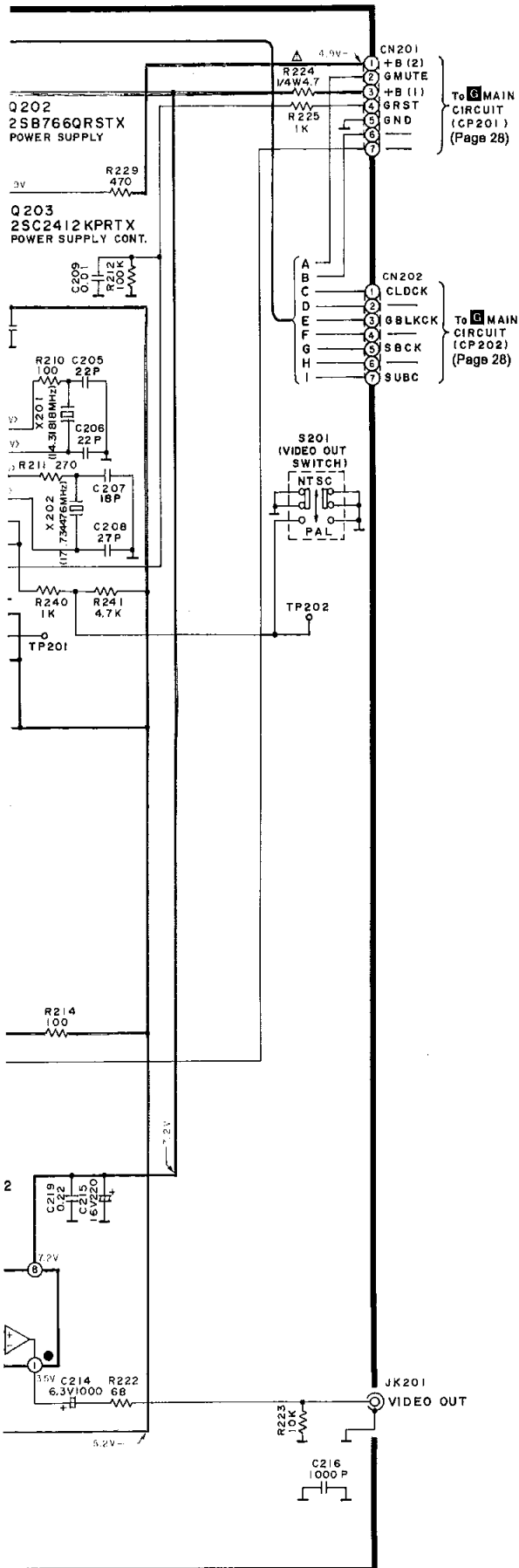

●Main/LED/Photo TR./Loading Motor/Operation/FL/Regulator TR. Circuit (Parts list on page 54~57)

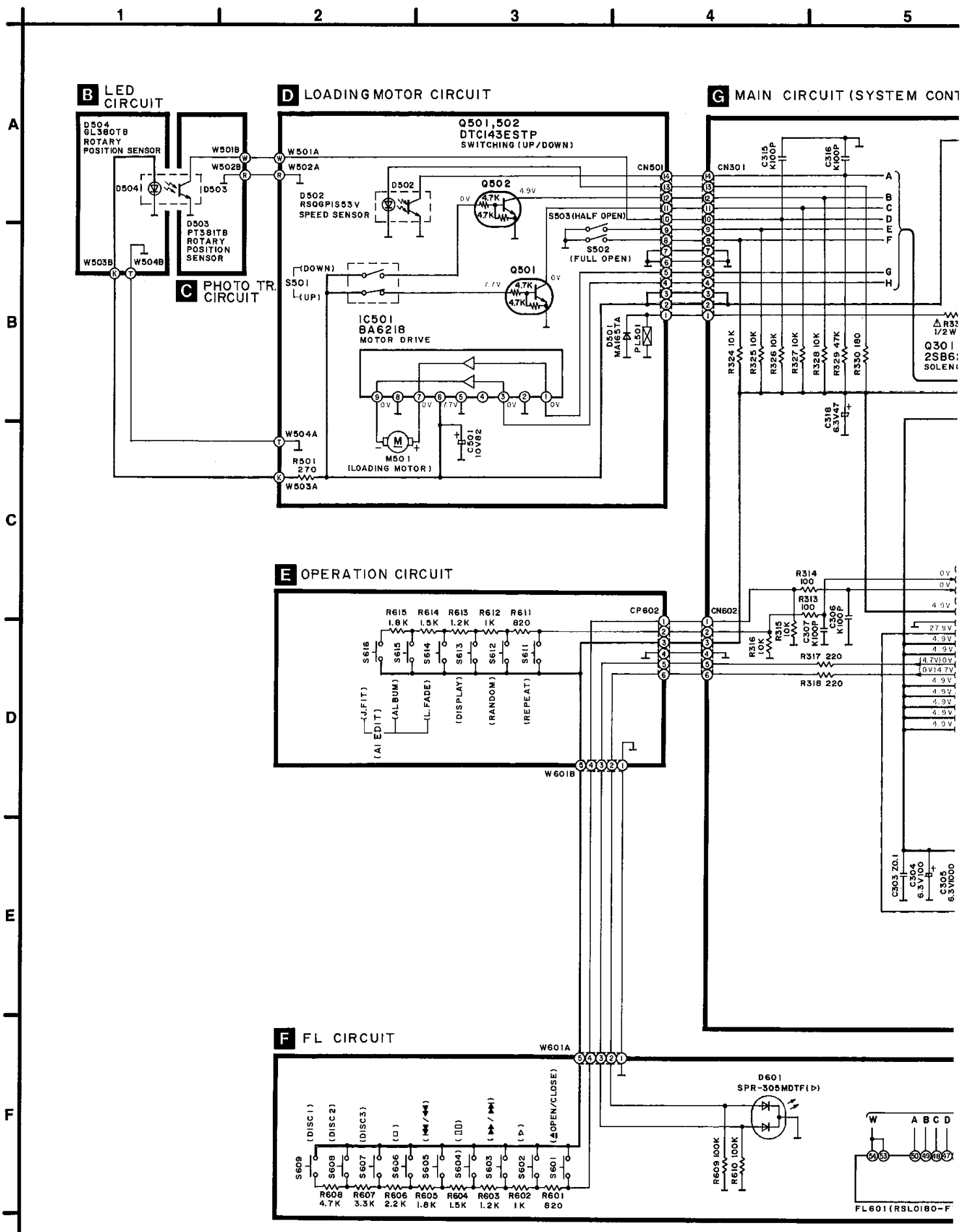

ROL / FL DRIVE / L.P. FILTER AMP / SWITCHING / REGULATOR

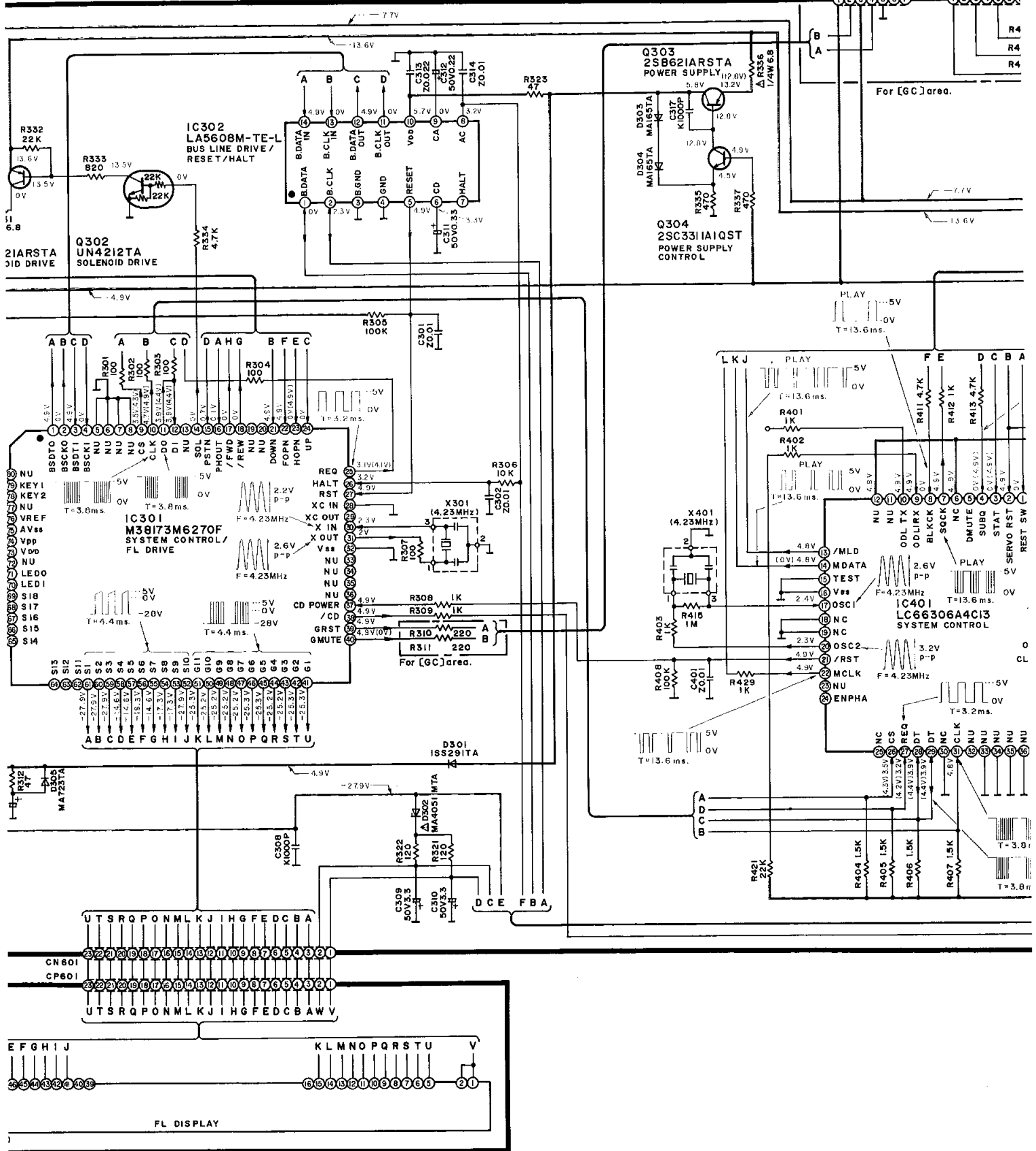

11

12

13

14

15

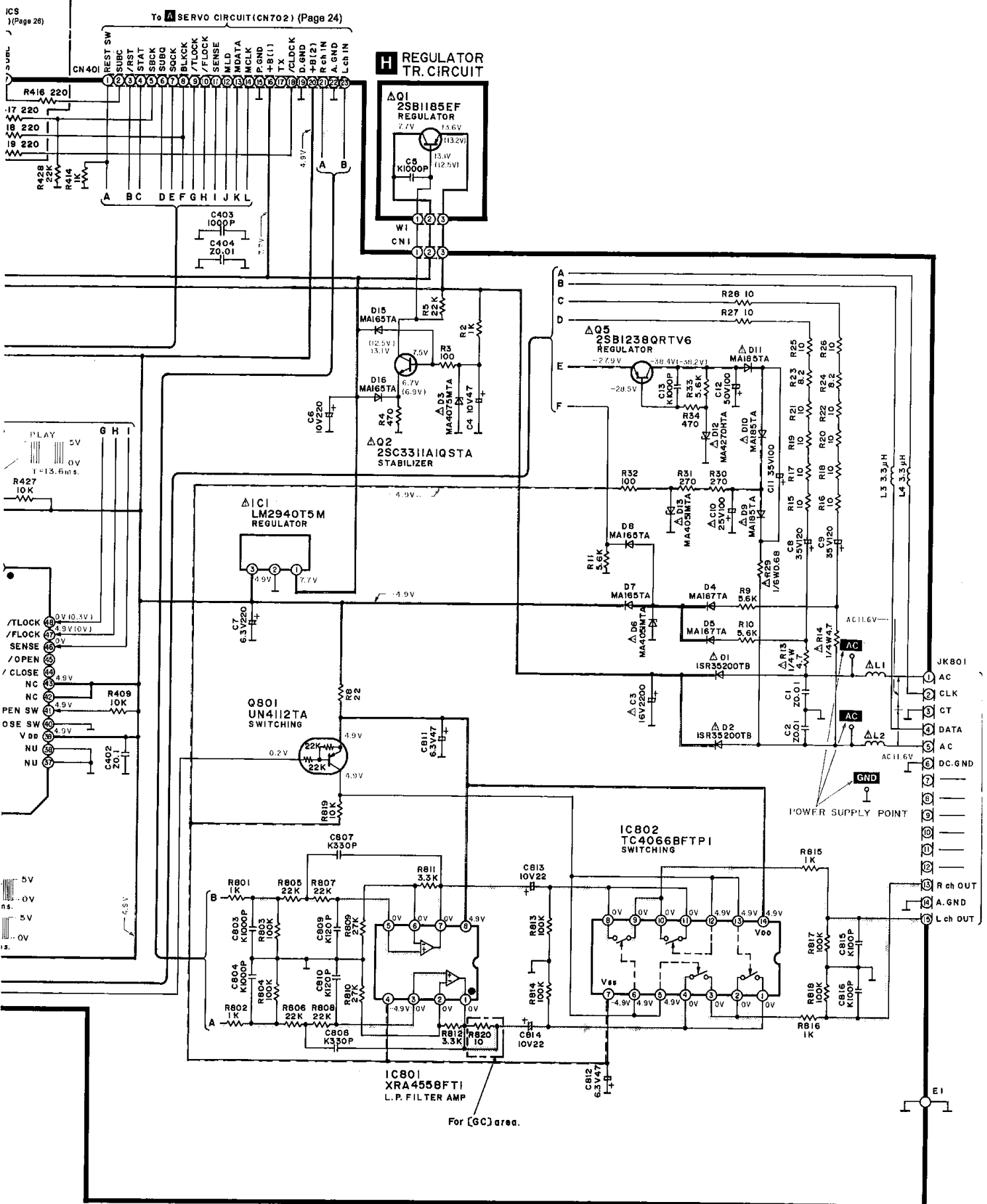

Notes:

- S201 : Video out switch (PAL/NTSC)
- S501 : Traverse deck position detect switch
- S502 : Disc tray full open detect switch
- S503 : Disc tray half open detect switch
- S601 : Loading drawer open/close switch (▲ OPEN/CLOSE)
- S602 : Play switch (▷)
- S603 : F.Skip/search switch (▶▶/▶▶I-SKIP/-SEARCH)
- S604 : Pause switch (⏸)
- S605 : R.Skip/search switch (◀◀/◀◀I-SKIP/-SEARCH)
- S606 : Stop switch (□)
- S607 : Disc switch (DISC 3)
- S608 : Disc switch (DISC 2)
- S609 : Disc switch (DISC 1)
- S611 : Repeat switch (REPEAT)
- S612 : Random play switch (RANDOM)
- S613 : Display switch (DISPLAY)
- S614 : CD edit switch (LAST FADE)
- S615 : CD edit switch (ALBUM)
- S616 : CD edit switch (J.FIT)
- S701 : Rest switch

●Indicated voltage values are the standard values for the unit measured by the DC electronic circuit tester (high-impedance) with the chassis taken as standard. Therefore, there may exist some errors in the voltage values, depending on the internal impedance of the DC circuit tester.

- No mark : CD STOP (S201:NTSC)
- () : CD PLAY [1kHz, L+R, 0dB (S201 : NTSC)]
- < > : CD STOP/PLAY [1kHz, L+R, 0dB (S201 : PAL)]

●Important safety notice:

Components identified by ▲ mark have special characteristics important for safety. Furthermore, special parts which have purposes of fire-retardant (resistors), high-quality sound (capacitors), low-noise (resistors), etc. are used. When replacing any of components, be sure to use only manufacturer's specified parts shown in the parts list.

Caution!

- IC and LSI are sensitive to static electricity.
- Secondary trouble can be prevented by taking care during repair.
- Cover the parts boxes made of plastics with aluminum coil.
- Ground the soldering iron.
- Put a conductive mat on the work table.
- Do not touch the legs of IC or LSI with the fingers directly.

●This schematic diagram may be modified at any time with the development of new technology.

●The supply part number is described alone in the replacement parts list.

Ref. No	Production Parts No.	Supply Parts No.
IC1	LM2940T5M	LM2940T5

- : Positive voltage line
- - - - : Negative voltage line
- ⊞⊞⊞⊞ : CD signal line

To ST-CH505: JK203 or
ST-CH707: JK203
/RS-CH505: JK1